

BOARD OF THE METROPOLITAN SEWERAGE DISTRICT
January 18, 2017

1. Call to Order and Roll Call:

The regular monthly meeting of the Metropolitan Sewerage District Board was held in the Boardroom of MSD's Administration building at 2pm Wednesday, January 18, 2017. Mr. Robert Pressley was appointed by Buncombe County to replace Mr. Joe Belcher, whose term expires after the January meeting. Mr. Pressley took the Oath of Office prior to the meeting. Chairman VeHaun presided with the following members present: Belcher, Bryson, Collins, Creighton, Frost, Kelly, Manheimer, Pelly, Pressley, Root and Wisler.

Others present were: Thomas E. Hartye, PE, General Manager; William Clarke, General Counsel; Brian Thorsvold with HDR Engineering; Joseph Martin with Woodfin Sanitary Water & Sewer District; Ed Bradford, Scott Powell, Hunter Carson, Matthew Walter, Jim Hemphill, Peter Weed, Ken Stines, Spencer Nay and Pam Nolan, MSD.

2. Inquiry as to Conflict of Interest:

Mr. VeHaun asked if there were any conflicts of interest with the agenda items. No conflicts were reported.

3. Approval of Minutes of the December 21, 2016 Board Meeting:

Mr. VeHaun asked if there were any changes to the Minutes of the December 21, 2016 Board Meeting. Ms. Frost moved for approval of the minutes as presented. Mr. Pelly seconded the motion. Voice vote in favor of the motion was unanimous.

4. Discussion and Adjustment of Agenda:

None

5. Informal Discussion and Public Comment:

Mr. VeHaun welcomed Mr. Thorsvold and Mr. Martin. There was no discussion or public comment.

6. Report of General Manager:

Mr. Hartye reported that MSD was notified that we have been selected to receive the 2017 National Environmental Achievement Award from the National Association of Clean Water Agencies (NACWA) at their February 6th annual conference. They are recognizing MSD's Emissions Upgrade Project at the Treatment Plant as being exemplary of their theme for the industry which is using innovation to affordably meet new compliance requirements. Mr. Hartye stated that this is a big deal for MSD because environmental engineering is what we do. We will return to the February Board Meeting to recognize this achievement.

Mr. Hartye reported that there is an attached e-mail from Lawson Sachter of Asheville commending Grady Brooks for his professionalism, kindness and making a fine experience for the Holidays. Thanks to Grady, Mickey Roberts and Travis Courtney.

Mr. Hartye also reported that the attached message was transcribed from a message left for him from Mr. Bob Gunn of Black Mountain stating that MSD has a great bunch of people and a good organization and our response is "jam up". Thanks to Mike Rice and Carl Ellington.

Mr. Hartye reported that MSD recently awarded a sewer rehabilitation project to line a portion of the old 36-inch concrete pipe through the Biltmore Estate. Due to favorable pricing and the Estate's short construction window, staff informally advertised for additional work. This work was budgeted for next year but is being moved up to take advantage of good pricing and timing.

Mr. Hartye reported the next regular Board Meeting will be held on February 15th at 2pm. The next Right of Way Committee meeting will be held on January 25, 2017 at 9am.

Mr. VeHaun welcomed new Board Member Robert Pressley representing Buncombe County, replacing Joe Belcher. He asked Mr. Pressley to come forward and presented him with the traditional manhole puller given to new Board Members.

7. Consolidated Motion Agenda:

a. Consideration of Annual Meeting Dates FY2017:

Mr. Hartye presented the Annual Meeting Dates for 2017. He reported that Board Meetings are typically the 3rd Wednesday of the month except during Budget. Planning Committee is ad hoc; Right-of-Way Committee is the 4th Wednesday. Personnel, Finance and CIP Committee are typically ad hoc but all meet during Budget.

b. Consideration of Budget Calendar FY 2017-18

Mr. Hartye presented the Budget Calendar for FY 2017-2018. Personnel Committee will meet April 25th at 9am to consider Cost of Living & Merit Pay and Benefit Allocations. CIP Committee will meet April 27th at 8:30am to consider an Update of the Ten-Year Capital Improvement Program, an Update to Construction Program Financing and the 2017-2018 Construction Fund Budget. Finance Committee will meet May 4th at 9am to consider the Nine Month Revenue/Expenditure Report, Self-Funded Medical and Dental Program, Proposed FY18 Construction Fund Budget and Proposed FY18 Operating Budget & Sewer Rates. The Board meets May 17th at 2pm to consider the

Preliminary FY18 Budgets and Sewer Rates and June 14th at 2pm for the Public Hearing and Adoption of the FY18 Budgets and Sewer Rates.

c. Consideration of Bids: Lining Contract No. 8:

Mr. Hartye reported that this project will rehabilitate lines which have been identified as problematic with root intrusion but only minor structural issues. These lining projects don't have to be "dig and replace" as most of the District's rehabilitation projects have to be. This contract consists of lining aged collector lines, rehabilitating associated manholes, and renewing the District maintained portions of service lines which are usually up to the clean out. This contract totals 10,143 LF. Seven bids were received on December 20, 2016 as follows: Layne Inliner, LLC in the amount of \$942,981.50; CaJenn Construction in the amount of \$940,127.00; Portland Utilities Construction in the amount of \$926,734.76; North American Pipeline in the amount of \$897,224.00; Terry Brothers Construction Company in the amount of \$879,685.00; VacVision Environmental in the amount of \$860,660.25; and IPR Southeast, LLC in the amount of \$777,622.50. IPR Southeast LLC is the apparent low bidder with a bid amount of \$777,622.50. IPR has not performed previous work for the District. Staff checked multiple references and all had favorable comments about their work. The Engineer's estimate for this portion of the work is about \$1 million. The original budget was \$1.375 million, a portion of which has had to be postponed due to access issues and will be done at a later time. Staff recommends award of this contract to IPR Southeast, LLC in the amount of \$777,622.50, subject to review and approval by District Counsel.

d. Consideration of Bids: Plant Headworks Project:

Mr. Hartye reported that the District recently had an update to the Plant Facility Plan and this project is one of the bigger projects straight out of the gate. This project is comprised of replacement bar screens at the head of the plant, a new fine screen and grit removal facility, as well as a surge system for wet weather storm events. He presented some images showing the location of the replacement of the grit facility, and explained where new fine screens and a grit removal facility will be located. He stated that the District is converting and re-purposing digester tanks which are 2 million gallons each for a surge system for large rain events. The construction budget for this project is approximately \$10.3 million over 2 years. The particularly onerous thing about this project is that it will require demolishing and replacing a lot of the area at the old chlorine building and connecting to existing piping. When you do those types of things it is very onerous and maintenance of plant operations is very critical. It would be easy to go out and build a plant when there is extra room, put in a new process while running the existing plant, tie pipes together when you are done and run it through the new plant. He stated that we are space limited with a river on one side and a rock bluff on the other which is why we have the design we

have now with the RBC's instead of the typical round tanks and aeration basins that other treatment plants have. To shoe horn all of our new improvements into the same plant footprint means you have to cut and re-attach pipes and demolish structures all while keeping the plant operating. This will be quite an ordeal over the next couple of years. Five bids were received on December 22, 2016 in the following amounts: State Utility Contractors, Inc. in the amount of \$10,680,000.00; Adams Robinson Enterprises, Inc. in the amount of \$9,847,000.00; Shook Construction Co., Inc. in the amount of \$9,604,347.00; Wharton-Smith Inc. in the amount of \$9,138,577.00; and Judy Construction Company in the amount of \$8,377,000.10. The apparent low bidder is Judy Construction Co. of Cynthiana, Kentucky with a bid amount of \$8,377,000.10. Judy Construction has not performed previous work for the District, however, they have performed many projects with HDR (the District's consulting engineer for this project). HDR has had significant positive experience with Judy Construction. Staff also performed a supplemental reference check which resulted in positive comments about Judy Construction from the three organizations that were contacted. The total construction budget for this project is \$10,328,000.00 over Fiscal Years 2017 and 2018. Staff recommends award of this contract to Judy Construction Company in the amount of \$8,377,000.10, subject to review and approval by District Counsel.

e. Consideration of Construction Administration Contract: Plant Headworks Project:

Mr. Hartye reported that HDR is the District's consulting engineer for the Plant Headworks Project discussed above. He stated that Brian Thorsvold with HDR is present. Mr. Thorsvold designed this project and is the project manager. District construction staff will perform most of the daily on-site inspection work; however, HDR will still be needed to perform specialized tasks and services. These will include review and approval of all construction submittals, monthly meetings, site inspections, technical assistance with requests for information, change orders and work change directives. HDR will also produce record drawings for the completed project. HDR is the most qualified consultant to perform the construction administration services. They submitted a lump sum fee of \$270,416.00 for Construction Administration Services over the 18-month period, which equates to about 3.2% of the construction contract. Staff believes this is a fair price considering what was explained with regard to the onerousness of trying to do this project and keep the plant operating at the same time. The construction administration budget for this project over Fiscal Years 2017 and 2018 totals \$368,000.00. Staff recommends award of the Construction Administration Contract to HDR Engineering in the amount of \$270,416.00, subject to review and approval by District Counsel.

f. Consideration of Developer Constructed Sewer Systems: Amboy Overlook Phase 1; Ingles No. 34-Sand Hill Road; Vance Place Drive; Woodcrest at Biltmore Terrace:

Mr. Hartye reported that the Amboy Overlook Phase 1 project included extending approximately 388 linear feet of 8-inch public gravity sewer to serve the 8 unit single family residential development.

Mr. Hartye reported that the Ingles No. 34-Sand Hill Road project included extending approximately 1,066 linear feet of 8-inch public gravity sewer to serve the commercial development.

Mr. Hartye reported that the Vance Place Drive project included relocating approximately 395 linear feet of 8-inch public gravity sewer and abandoning approximately 171 linear feet of existing public gravity sewer to serve the 6 unit single family residential development.

Mr. Hartye reported that the Woodcrest at Biltmore Terrace project included extending approximately 203 linear feet of 8-inch public gravity sewer to serve the 8 unit single family residential development.

Staff recommends acceptance of the aforementioned developer constructed sewer systems. All MSD requirements have been met.

g. Cash Commitment/Investment Report Month ended November, 2016:

Mr. Powell reported that Page 42 presents the makeup of the District's Investment Portfolio. There has been no significant change in the makeup of the portfolio from the prior month. Page 43 presents the MSD investment managers report for the month of November. The weighted average maturity of the investment portfolio is 181 days. The yield to maturity is .82% and exceeds our bench mark of 6 month T-Bill and North Carolina Capital Management Trust cash portfolio. Page 44 presents an analysis of the District's cash receipts. YTD and Monthly domestic and industrial sewer revenues are considered reasonable based on timing of cash receipts in their respective fiscal periods. YTD facility and tap fees are considered reasonable based on the conservative nature in budgeting and in addition to us receiving approximately 2 million from 7 developments. That's the reason that percentage is elevated over 200%. Mr. Belcher stated that was a pretty big jump. Mr. Powell stated that it was a big jump but the jump is in comparison to the Budget. If we had these numbers in the respective year periods in comparison to the Budget, those would be up just as much. Mr. Belcher stated it was not a big deal; it's been like that pretty much every year that he has been here. Mr. Hartye stated they are non-recurring fees so we make that conservative because you don't know when development is going to occur. That's something you really can't plan for or you can get burned if you do. That all gets carried over into construction funds for the next

year. Mr. Root asked regarding the percentage fee, any idea how much money this is. Mr. Powell stated that in November that was in excess of \$3 million dollars. Mr. Root asked if we tend to suspect every year that extra money is going to come in. Mr. Powell stated no we do not. He further stated that as Finance Director, he is budgeting \$1.5 million and that is how we set the rate structure. Have we had years that have been above that amount? Absolutely, but not that dramatic. Last fiscal year and this fiscal year are the two that have been of that type of magnitude. It is usually more like \$2.4 or \$2.5. Mr. Root asked if we lowered our expectations during the recession and not brought it back up again. Mr. Powell stated we always had the same expectation through-out the recession and other time periods. Mr. Clarke stated that one reason it is budgeted conservatively is when figuring net revenue the MSD bond order doesn't allow MSD to include facility fees. You could take action to change that but historically when you are figuring net revenues for purposes of debt coverage, bond ratings, etc., it's not included. Mr. Powell further stated that a lot of this is the nature of the developments. In the past everything was residential development. Now it's more apartment driven. Ms. Manheimer stated that she did hear complaints about that fee on the City side from developers because they have to pay per unit and they get a pretty big bill but we have discussed this and apparently it's normal. Mr. Clarke stated that it was lower than many other communities. Mr. Powell reported that Page 45 is an analysis of the District's Expenditures. O&M, Debt Service and Capital Projects expenditures are considered reasonable based on historical trends and timing of capital projects. Page 46 presents the MSD Variable Debt Service report. Both the 2008A Series bonds are performing better than budgeted expectations. As of the end of December this issue has saved the District rate payers approximately \$4.8 million in debt service since April, 2008. There were no questions pertaining to this item.

With no further discussion, Mr. VeHaun called for a motion to approve the Consolidated Motion Agenda. Mr. Pelly moved. Mr. Root seconded the motion. Roll call vote was as follows: 11 Ayes; 0 Nays.

8. **Old Business:** None
9. **New Business:**

Mr. VeHaun stated that he had one item of new business since Mr. Belcher would be leaving the Board. There will be a lunch held on February 15, 2017 at 1:15pm, before the 2pm Board Meeting.

10. **Adjournment:**

With no further business, Mr. VeHaun called for adjournment at 2:25 pm.

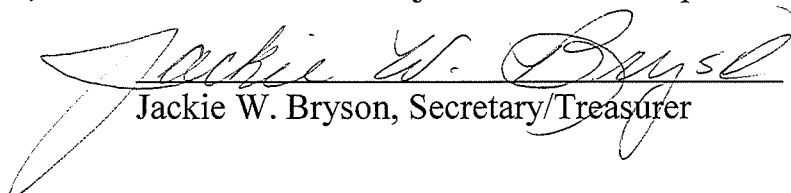
Jackie W. Bryson, Secretary/Treasurer

MSD

Regular Board Meeting

Metropolitan Sewerage District
of Buncombe County, NC

AGENDA FOR 1/18/17

✓	Agenda Item	Presenter	Time	
	Call to Order and Roll Call	VeHaun	2:00	
	01. Inquiry as to Conflict of Interest	VeHaun	2:05	
	02. Approval of Minutes of the December 21, 2016 Board Meeting	VeHaun	2:10	
	03. Discussion and Adjustment of Agenda.	VeHaun	2:15	
	04. Informal Discussion and Public Comment	VeHaun	2:20	
	05. Report of General Manager	Hartye	2:25	
	06. Consolidated Motion Agenda		2:30	
	a. Consideration of Annual Meeting Dates FY2017	Hartye		
	b. Consideration of Budget Calendar FY2017-18	Hartye		
	c. Consideration of Bids: Lining Contract No. 8	Hartye		
	d. Consideration of Bids: Plant Headworks Project	Hartye		
	e. Consideration of Construction Administration Contract: Plant Headworks Project	Hartye		
	f. Consideration of Developer Constructed Sewer Systems: Amboy Overlook Phase 1; Ingles No. 34 – Sand Hill Road; Vance Place Drive; Woodcrest at Biltmore Terrace	Hartye		
	g. Cash Commitment/Investment Report Month Ended November, 2016	Powell		
	07. Old Business:	VeHaun	3:00	
	08. New Business:	VeHaun	3:15	
	09. Adjournment: (Next Meeting 2/15/17)	VeHaun	3:25	
	STATUS REPORTS			

BOARD OF THE METROPOLITAN SEWERAGE DISTRICT
December 21, 2016

1. Call to Order and Roll Call:

The regular monthly meeting of the Metropolitan Sewerage District Board was held in the Boardroom of MSD's Administration building and called to order at 2:02 pm on Wednesday, December 21, 2016. Chairman VeHaun presided with the following members present: Ashley, Belcher, Bryson, Collins, Frost, Kelly, Manheimer, Pelly, Root and Wisler.

Others present were: Thomas E. Hartye, PE, General Manager; William Clarke, General Counsel; Forrest Westall with McGill Associates; Ed Bradford, Scott Powell, Hunter Carson, Matthew Walter, Jim Hemphill, Mike Stamey, Ken Stines and Pam Nolan, MSD.

2. Inquiry as to Conflict of Interest:

Mr. VeHaun asked if there were any conflicts of interest with the agenda items. No conflicts were reported.

3. Approval of Minutes of the November 16, 2016 Board Meeting:

Mr. Vahaun asked if there were any changes to the Minutes of the November 16, 2016 Board Meeting. Ms. Wisler moved for approval of the minutes as presented. Ms. Frost seconded the motion. Voice vote in favor of the motion was unanimous.

4. Discussion and Adjustment of Agenda:

None

5. Informal Discussion and Public Comment:

There was no discussion or public comment.

6. Report of General Manager:

Mr. Hartye thanked Roger Edwards who heads up operations at the treatment plant. Roger gives excellent plant tours to the public amongst his many duties and responsibilities. A lot of schools avail themselves of this opportunity as far away as Greenville, SC. This year MSD had 33 tours with over 434 attendees. Mr. Hartye reported that John Fisher of Rodgers Place emailed in to thank Roy Lytle, Billy Cantrell, Marvin Felder and Nicolas Hercules. The MSD United Way campaign raised over \$20,000 this year between pledges and the annual golf tournament. Thanks to all who helped with the campaign and contributed. Thanks to Jim Hemphill for heading up the effort. Mr. Hartye reported that there is a copy of an answer man piece attached regarding the French Broad River during the drought and the MSD Treatment Plant. Even in dry times MSD's discharge has never been over 2 percent of the river flow, most of the time it's closer to 2/1000. Mr. Kelly asked if there was a video tour of the plant available on line. Mr. Hartye

stated that there is a virtual tour similar to a power point presentation available on the MSD website with written descriptions of what you are seeing.

Mr. Hartye reported the next regular Board Meeting will be held on January 18th at 2 pm. The next Right of Way Committee meeting will be held on January 25, 2017 at 9 am.

7. Consolidated Motion Agenda:

a. Consideration of Bids: Sand Hill Road @ Russell/Davenport Sanitary Sewer Rehabilitation Project, MSD Project No. 2011093

Mr. Hartye reported that this project is located in West Asheville and consists of replacing a problematic 8-inch clay line which is structurally deficient. This line is in close proximity to a creek and has a high Pipe Rating value. The contract was advertised and three bids were received on December 1, 2016, in the following amounts: North American Pipeline Management in the amount of \$941,107.00; Thunder Contracting, Inc. in the amount of \$592,548.50; and Terry Brothers Construction Company in the amount of \$425,089.00. The apparent low bidder is Terry Brothers Construction Company in the amount of \$425,089.00. The FY 16-17 Construction Budget for this project is \$520,000.00. Staff recommends award of this contract to Terry Brothers Construction Company in the amount of \$425,089.00, subject to review and approval by District Counsel.

b. Consideration of Developer Constructed Sewer Systems: Asheville Middle School; Bowen Estates; 500 Fairview Road; Roberts Farm Phase 1B and Mallard Run Phase 2

Mr. Hartye reported that the Asheville Middle School project included extending approximately 215 linear feet of 8-inch public gravity sewer and abandoning approximately 575 linear feet of public sewer to accommodate and serve the new school.

Mr. Hartye reported that the Bowen Estates project included extending approximately 173 linear feet of 8-inch public gravity sewer to serve the new four unit single family residential development.

Mr. Hartye reported that the 500 Fairview Road project is located in the City of Asheville and included relocating approximately 220 linear feet of 8-inch public gravity sewer and abandoning approximately 240 linear feet of public sewer to accommodate and serve the nine unit single family residential development.

Mr. Hartye reported that the Roberts Farm Phase 1B project is located off Byrd Road in the Town of Black Mountain. This project included extending approximately 230 linear feet of 8-inch public gravity sewer to serve a 16 unit single family subdivision.

Mr. Hartye reported that the Mallard Run Phase 2 project included extending approximately 1,220 linear feet of 8-inch public gravity sewer to serve a 36 unit residential development.

Staff recommends acceptance of the aforementioned developer constructed sewer systems. All MSD requirements have been met.

c. Cash Commitment/Investment Report Month ended October, 2016:

Mr. Powell reported that Page 28 presents the makeup of the District's Investment Portfolio. There has been no change in the makeup of the portfolio from the prior month. Page 29 presents the MSD investment managers report for the month of October. The weighted average maturity of the investment portfolio is 179 days. The yield to maturity is .75% and exceeds our bench mark of 6 month T-Bill and North Carolina Capital Management Trust cash portfolio. Page 30 presents the MSD analysis of Cash Receipts. Domestic User Fees and Industrial Revenue are considered reasonable based upon timing of cash receipts and historical trends. Facility and Tap Fees are above budgeted expectations due to receiving \$1.7 million from four developers in the current fiscal year. Page 31 presents the analysis of Expenditures. O&M, Debt Service and Capital Projects expenditures are considered reasonable based on historical trends and timing of cash expenditures. Page 32 presents the Variable Debt Service report. The 2008 Series bonds are performing better than budgeted expectations. As of the end of November this issue has saved the District rate payers over \$4.8 million in debt service. There were no questions pertaining to this item.

d. Consideration of Amendment to Standby Bond Purchase Agreement:

Mr. Powell stated that this item is in relation to the Variable Rate Interest swap. Because the District's 2008A Series Revenue Refunding Bonds are variable rate debt, the District has to have a Standby Bond Purchase Agreement. A Standby Purchase agreement is an agreement with a third party, typically a bank, in which the bank agrees to purchase our variable rate debt tendered for purchase in the event the bonds cannot be remarketed. Staff informally investigated the Stand By Purchase Agreement market and looked at rate and terms. This information was used to negotiate a .40% rate and an extension of the current Standby Bond Purchase Agreement to February 2020 with its current provider, Wells Fargo NA. The District will have to spend \$2,500.00 in legal fees and will save approximately \$27,000.00 over the life of the Agreement. Mr. Powell reported that there is a letter attached

Minutes

December 21, 2016

Page Four

from Wells Fargo outlining this amendment. Staff recommends the endorsement of the proposed amendment from Wells Fargo, NA subject to review and approval by District Counsel.

With no further discussion, Mr. VeHaun called for a motion to approve the Consolidated Motion Agenda. Ms. Frost moved. Mr. Belcher seconded the motion. Roll call vote was as follows: 11 Ayes; 0 Nays.

8. Old Business:

Mr. Clarke reported that the Supreme Court, in a 5-2 decision, had reversed the decision of the North Carolina Court of Appeals that found House Bill 488 constitutional. The Supreme Court ruled that House Bill 488 was a local act regulating health and sanitation and thus violative of Article II, Section 24 of the North Carolina Constitution. Ms. Frost asked how much had been spent on legal bills to date. Ms. Manheimer said she was not sure at this point.

9. New Business: None

10. Adjournment:

With no further business, Mr. VeHaun called for adjournment at 2:17 pm.

Jackie W. Bryson, Secretary/Treasurer



MEMORANDUM

TO: MSD Board
FROM: Thomas E. Hartye, P.E., General Manager
DATE: January 13, 2017
SUBJECT: Report from the General Manager

- 2017 National Environmental Achievement Award

MSD was notified that we have been selected to receive the 2017 National Environmental Achievement Award from the National Association of Clean Water Agencies (NACWA) at the February 6th annual conference. NACWA has recognized our Emissions Upgrade Project at the Treatment Plant as being exemplary of the 2017 theme for our industry - using innovation to affordably meet new compliance requirements. This is a big deal for MSD because environmental engineering is what we do. We will return to the February Regular Board Meeting to recognize this achievement.

- Kudos

- See the attached email from Lawson Sachter of Asheville commending Grady Brooks along with Mickey Roberts and Travis Courtney.
- Please see the attached message from Bob Gunn of Black Mountain. Thanks to Mike Rice and Carl Ellington.

- Interceptor Rehab Project

The District recently awarded a sewer rehabilitation project to line a portion of the old 36-inch concrete pipe through the Biltmore Estate. Due to very favorable pricing and the Estate's short construction window, staff informally advertised for additional work. This work was already budgeted in the FY17-18 CIP, so this is being accelerated to take advantage of good pricing and timing.

- Board/Committee Meetings/Events

The next Regular Board Meeting will be held on February 15th at 2 pm. The next Right of Way Committee meeting will be held on January 25, 2017 at 9am.

EXECUTIVE COMMITTEE
PRESIDENT

Raymond J. Marshall
Executive Director
Narragansett Bay
Commission
Providence, RI

VICE PRESIDENT

Cathy Gerali
District Manager
Metro Wastewater
Reclamation District
Denver, CO

TREASURER

David St. Pierre
Executive Director
Metropolitan Water
Reclamation District of
Greater Chicago
Chicago, IL

SECRETARY

Mark S. Sanchez
Executive Director
Albuquerque-Bernalillo
County Water
Utility Authority
Albuquerque, NM

PAST PRESIDENT

Adel H. Hagekhalil
Assistant Director
City of Los Angeles -
LA Sanitation
Los Angeles, CA

CHIEF EXECUTIVE OFFICER

Adam Krantz

December 20, 2016

Thomas E. Hartye
MSD General Manager
Metropolitan Sewerage District of Buncombe County
2028 Riverside Drive
Asheville, NC 28804

Dear Tom:

Congratulations again on your selection to receive a 2017 *National Environmental Achievement Award (NEAA)*.

As an NEAA honoree, you will be recognized at an evening Awards Ceremony & Reception on Monday, February 6, 2017, during NACWA's Winter Conference, *Next Generation Compliance ... Where Affordability & Innovation Intersect*, held February 4-7, 2017 at the Tampa Marriott Waterside Hotel in Tampa, Florida.

Attached is information detailing the ceremony logistics, as well as an important response form. Please complete and return this form as soon as possible, but **no later than January 9, 2017**. Information regarding the Winter Conference including the agenda, registration, and hotel details are available on NACWA's website (www.nacwa.org/17winter). If you have not already done so, we encourage you to make your reservation without delay.

NACWA will notify any public officials noted on your application of this honor. In addition, public relations resources to assist you in promoting your award are being developed and will be available on the awards section of the NACWA website on January 9th.

It will be NACWA's honor to present you with this prestigious honor. We are proud to celebrate your clear commitment to clean water and look forward to seeing you in Tampa this February!

Sincerely,



Edward G. Henifin
Chair, NACWA Awards Committee
General Manager
Hampton Roads Sanitation District, VA



Adam Krantz
Chief Executive Officer
NACWA

Re: Message on Tom Hartye's voice mail from Bob Gunn, 109 Pleasant Drive,
Black Mountain – Tuesday, January 3, 2017

“Good Morning Tom, my name is Bob Gunn and I live in Black Mountain. I’ve been wanting to speak to you or give you a message for quite some time so I’m finally doing it. Had a little sewer problem yesterday, called, and in just about an hour, Mike and another fella came out and took care of the problem very quickly and promptly. Tom, As far as I’m concerned MSD is the finest, most well managed public service utility type operation I have ever had the pleasure of being served by. Every time I’ve had occasion to call you fellas, the response has just been jam up, prompt, thorough and solves the problem. I just wanted you to know what a great bunch of people you have working for you and how much I appreciate everything ya’ll do. There is no need to call me back but if you want to my number is 669-0274, if you need a little more information. Thank you so much for all that you do.”

Subject: FW: Grady's Kindness

Date: Thursday, January 12, 2017 at 1:48:44 PM Eastern Standard Time

From: Tolley, Lisa

To: Hartye, Tom

CC: Thomas, Pam

[W:239252 Grady Brooks](#)

[W:239253 Mickey Roberts, Travis Courtney](#)

From: Stines, Ken

Sent: Thursday, January 12, 2017 12:39 PM

To: Tolley, Lisa

Subject: FW: Grady's Kindness

From: Lawson Sachter [<mailto:dhsachter@aol.com>]

Sent: Thursday, January 12, 2017 7:44 AM

To: Stines, Ken

Subject: Grady's Kindness

Dear Mr. Stines,

I'd like to commend Grady for his courteous professionalism in cleaning out the street level sewer line at my daughter's house on Deerwood Drive.

Because of a poor connection under the street her sewer completely backed up on the afternoon of Christmas Eve, and it appeared that the only thing that was going to go down the drain was our family plans.

But then at 5:00 that evening, Grady showed up and went to work. He was Great, but even with all his knowhow he had to get the rest of his crew to come with their machine to cut through the mess. They were all so kind and helpful it was really a fine experience, and without their help who knows how the holidays would have gone...

It's no secret that good people are hard to find, and so I wanted you to know how much Grady and his crew were appreciated, not only by me, but by our whole family!

With thanks,
David Sachter
36 Deerwood Drive
Asheville, NC 28805

**METROPOLITAN SEWERAGE DISTRICT
ANNUAL MEETING DATES
2017**

BOARD MEETINGS – 2:00 PM

January 18

February 15

March 15

April 19

May 17

June 21

July 19

August 16

September 20

October 18

November 15

December 20

COMMITTEE MEETINGS - (See Budget Calendar)

Planning Committee - As needed by notice.

Right of Way Committee - 4th Wednesday of each month at 9 a.m. No meeting in December.

Personnel Committee - As needed by notice. (See Budget Calendar)

Finance Committee - As needed by notice (See Budget Calendar)

CIP Committee - Annual – (See Budget Calendar)

Metropolitan Sewerage District of Buncombe County BOARD ACTION ITEM

Meeting Date: January 18, 2017
Submitted By: Thomas E. Hartye, PE., General Manager
Prepared By: W. Scott Powell, CLGFO Director of Finance
Subject: Adoption of Budget Calendar – FY2017-2018

Background

The District's budget process must satisfy requirements in the North Carolina General Statutes as well as the 1999 Amended and Restated Bond Order. NC statutes require an annual balanced budget ordinance based upon expected revenues, along with a budget message to be presented to the governing board no later than June 1. Thereafter, the budget must be adopted no earlier than 10 days after the budget is first presented to the Board and not later than July 1. The Bond Order calls for the budget to be adopted by the Board on or before June 15.

Discussion

The attached budget calendar is designed to allow for input by all stakeholders into a systematic and deliberate process. Time between committee and board meetings has been scheduled to prepare and distribute agenda items, including preparation time for any revisions requested to be presented at a subsequent meeting.

The Finance Committee meeting to discuss the proposed budget is scheduled for May 4th with the expectation that fairly firm estimates of health and other insurance renewal care costs will be available by the middle of April.

This calendar is a guide and committee meetings may be added and/or rescheduled as necessary to accommodate the Preliminary Budget being presented on May 17 and the Final Budget being adopted on June 14.

Fiscal Impact

None.

Staff Recommendation

Approval of the proposed Budget Calendar.

Action Taken

Motion by:	to	Approve	Disapprove
Second by:		Table	Send to Committee
Other:			
Follow-up required:			
Person responsible:		Deadline:	

Budget Calendar FY 2018

April

S	M	T	W	T	F	S
						1
2	3	4	5	6	7	8
9	10	11	12	13	14	15
16	17	18	19	20	21	22
23	24	25	26	27	28	29
30						

May

S	M	T	W	T	F	S
	1	2	3	4	5	6
7	8	9	10	11	12	13
14	15	16	17	18	19	20
21	22	23	24	25	26	27
28	29	30	31			

June

S	M	T	W	T	F	S
				1	2	3
4	5	6	7	8	9	10
11	12	13	14	15	16	17
18	19	20	21	22	23	24
25	26	27	28	29	30	

July

S	M	T	W	T	F	S
						1
2	3	4	5	6	7	8
9	10	11	12	13	14	15
16	17	18	19	20	21	22
23	24	25	26	27	28	29
30	31					

DATE	TIME	SUBJECT
April 25	9:00 a.m.	Personnel Committee Meeting
		<ul style="list-style-type: none"> Cost of Living & Merit Pay Benefit Allocations
April 27	8:30 a.m.	CIP Committee Meeting
		<ul style="list-style-type: none"> Update of Ten-Year Capital Improvement Program Update Construction Program Financing 2017-2018 Construction Fund Budget
May 4	9:00 a.m.	Finance Committee Meeting
		<ul style="list-style-type: none"> Nine Month Revenue/Expenditure Report Self-Funded Medical & Dental Program Proposed FY18 Construction Fund Budget Proposed FY18 Operating Budget & Sewer Rates
May 17	2:00 p.m.	Board Meeting
		<ul style="list-style-type: none"> Preliminary FY18 Budgets & Sewer Rates
June 14	2:00 p.m.	Board Meeting
		<ul style="list-style-type: none"> Public Hearing Adoption of FY18 Budgets & Sewer Rates
July 1		Start of Fiscal Year 2017-2018

Metropolitan Sewerage District of Buncombe County

BOARD ACTION ITEM

BOARD MEETING DATE: 1/18/17

SUBMITTED BY: Tom Hartye, P.E. - General Manager

PREPARED BY: Ed Bradford, P.E. - Director of CIP
Darin Prosser, P.E. - Project Manager

SUBJECT: Consideration of Bids: Lining Contract No. 8, MSD Project Number 2015218

BACKGROUND: This project will rehabilitate lines which have been identified as problematic (particularly with root intrusion), but with only minor structural issues. The District's Pipe Rating Program is utilized to help determine the structural condition of the various lines, then pipes are individually evaluated by an engineer for possible rehabilitation options.

This contract is the eighth of the District's lining contracts. It consists of lining aged clay collector lines; rehabilitating associated manholes; and renewing the District-maintained portions of all service lines. Lines are located at various sites within the county, with the majority being in the Oakley area. This contract totals 10,143 LF.

Seven bids were received on December 20, 2016 for this contract in the following amounts:

<u>Contractor</u>	<u>Total</u>
1) Layne Inliner, LLC	\$ 942,981.50
2) CaJenn Construction	\$ 940,127.00
3) Portland Utilities Construction	\$ 926,734.76
4) North American Pipeline	\$ 897,224.00
5) Terry Brothers Const. Co.	\$ 879,685.00
6) VacVision Environmental	\$ 860,660.25
7) IPR Southeast, LLC	\$ 777,622.50

The apparent low bidder is IPR Southeast, LLC with a bid amount of \$777,622.50. IPR has not performed previous work for the District; therefore staff checked multiple references, and all had favorable comments about their work.

The FY16-17 budget of \$1,375,000 was originally based on line segments that were in difficult locations and terrain. Due to the access problems and required tree removal in these areas, staff will work with property owners to create access to the manholes and line these segments in a future lining contract.

Please refer to the attached documentation for more detailed information, including the reference check.

FISCAL IMPACT: The FY16-17 construction budget is \$1,375,000.00.

STAFF RECOMMENDATION: Staff recommends award of this contract to IPR Southeast, LLC. in the amount of \$777,622.50, subject to review and approval by District Counsel.

**METROPOLITAN SEWERAGE DISTRICT OF
BUNCOMBE COUNTY, NORTH CAROLINA**

**LINING CONTRACT NO. 8 SEWER REHABILITATION
PROJECT NO. 2015218**

**BID TABULATION
December 20, 2016**

BIDDER	Bid Bond	MBE Form	Bid Forms (Proposal)	TOTAL BID AMOUNT
Layne Inliner, LLC Gastonia, NC	5%	1	Yes	\$942,981.50
CaJenn Construction & Rehabilitation Hoboken, GA	5%	2	Yes	\$940,127.00
Portland Utilities Construction Company Portland, TN	5%	1	Yes	\$926,734.76
North American Pipeline Management Greenville, SC	5%	1	Yes	\$897,224.00
Terry Brothers Constructon Company Leicester, NC	5%	1	Yes	\$879,685.00
VacVision Environmental Tampa, FL	5%	none	Yes	\$860,660.25
IPR Southeast, LLC Stone Mountain, GA	5%	1	Yes	\$777,622.50

APPARENT LOW BIDDER

Darin Prosser, P.E.
Project Engineer
Metropolitan Sewerage District of
Buncombe County, North Carolina

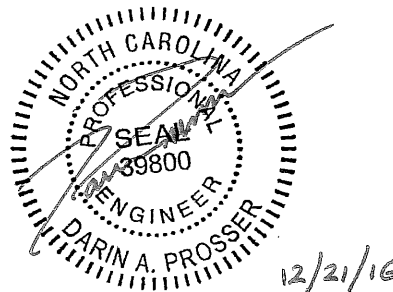

This is to certify that the bids tabulated herein were publicly opened and read aloud at 2:00 p.m. on the 20th day of December 2016, in the W.H. Mull Building at the Metropolitan Sewerage District of Buncombe County, Asheville, North Carolina, and that said bids were accompanied by acceptable bidders bonds in the amount of 5% of the bid.

Interoffice Memorandum

TO: Tom Hartye, General Manager

FROM: Ed Bradford, Director of Engineering
Darin Prosser, Project Manager

DATE: January 3, 2017

RE: Lining Contract No. 8 Sewer Rehabilitation; MSD Project No. 2015218

This project will be the District's eighth pipe lining project. The work is comprised of numerous line segments which have been identified as having significant root intrusion and minor structural problems that create infiltration. These line segments are located at various locations in Buncombe County. The majority of the lining segments are located in the Oakley area of East Asheville. Each of the line segments has been reviewed using CCTV data to determine methods of rehabilitation.

This contract consists of the rehabilitation of existing collector sewers using the "Cured in Place" method of trenchless rehabilitation. It consists of approximately 9,995 LF of 8" lining and 148 LF of 12" lining for a total of 10,143 LF. In addition to the lines, the manholes on these segments will be rehabilitated or replaced and the services will be replaced.

On December 20, 2016, seven (7) sealed bids were received at 2:00 pm. The results were as follows:

<u>Contractor</u>	<u>Bid Amount</u>
1) Layne Inliner, LLC	\$ 942,981.50
2) CaJenn Construction	\$ 940,127.00
3) Portland Utilities Construction	\$ 926,734.76
4) North American Pipeline	\$ 897,224.00
5) Terry Brothers Const. Co.	\$ 879,685.00
6) VacVision Environmental	\$ 860,660.25
7) IPR Southeast, LLC	\$ 777,622.50

The apparent low bidder is IPR Southeast, LLC with a bid amount of \$777,622.50. The FY16-17 construction budget for this project is \$1,375,000.00. This budget was originally based on line segments that were in different locations in hard to access terrain that would have required right of way clearing. Additionally, there were twice as many manholes that would have required replacement or rehabilitation at the original locations.

Since IPR Southeast, LLC has not performed work for the District in the past; references were checked to confirm quality of work, experience and reputation of project management, timeliness of project completion, and to confirm that work was performed within budget. Five references were contacted and all provided positive feedback on IPR Southeast.

Staff recommends award of this contract to IPR Southeast, LLC contingent upon review and approval by District Counsel.

Lining Contract No. 8

MSD Project No. 2015218

Reference Check for IPR Southeast, LLC, January 2017

Spartanburg, SC Water District

Sanitary Sewer Rehabilitation – Phase 2 (September 2016)

4,400 LF of 8” CIPP

Brian Smith, engineer for Spartanburg Water District, said that this was the second project he has worked with IPR and has no complaints. IPR has completed projects on time and within budget. He also mentioned that the field personnel have been professional in all interactions. Brian stated that the liners appeared to be properly sized with very few wrinkles and there are no signs of any tears. Overall, he gave IPR a very positive reference.

City of Greenville, SC

Basins 9, 17, & 19 Both Water (August 2016)

19,416 LF of 8” to 15” CIPP

Clark Chewning, engineer for City of Greenville, said that IPR does great work and they are very efficient and quick. The liner was fit properly and there were minimal wrinkles. Clark did say he had issues with the original supervisor but there were no problems after the supervisor was replaced. He also stated IPR was slow with paper work and the liner test data. Clark said overall, IPR was great to work with and did a fantastic job.

City of Mauldin, SC

2015 Mauldin, SC Sewer Bond Project (July 2016)

20,000 LF of 8” CIPP

Aaron Frazier, owner and engineer of Frazier Engineering, said that he has worked with IPR for years and they do very good work. IPR's management and personnel have been fine and they are generally on time and within budget. He stated that IPR has always made things right if there were any problems on the project without arguing or submitting claims. Aaron said he was always pleased to see IPR as the low bidder on his projects.

City of Chattanooga, TN

Annual CIPP Lining Services (June 2014)

Work Order Based Contract of 8” to 15” CIPP

Eric Sluder, project manager for City of Chattanooga, said IPR is working on their annual CIPP lining contract that is an as needed based contract. Majority of the time, the lining consists of 300 LF to 1,000 LF jobs. Due to the small jobs, IPR is slow to mobilize and get to the job. However, once IPR is at the job site, they do great work and are very professional.

Gwinnett, GA County Department of Water

Gwinnett Sanitary Sewer and Force Main Rehabilitation Program (February 2014)

10,000 LF of 8” CIPP

Jeff Callaway, construction manager for Gwinnett County Department of Water, said that IPR did a good job and would work with them again. Their personnel were professional and knowledgeable. The supervisor did measure the existing pipes for proper liner size and there were minimal wrinkles. The only hiccup IPR had was when a truck broke down and stopped work for a week.

**Metropolitan Sewerage District of Buncombe County, North Carolina
CAPITAL IMPROVEMENT PROGRAM**

BUDGET DATA SHEET - FY 2016 - 2017

PROJECT: Lining Contract No. 8	LOCATION: Various
TYPE: General Sewer Rehab	PIPE RATING: NA
PROJECT NO. 2015218	TOTAL LF: 11,000
PROJECT BUDGET: \$1,377,000.00	PROJECT ORIGIN: Access, Line condition

DESCRIPTION	ESTIMATED PROJECT COST	TOTAL EXPENDS THRU 12/31/15	EST. COST JAN - JUNE 2016	BUDGET FY 16-17
55310 - PRELIM. ENGINEERING				
55320 - SURVEY - DESIGN				
55330 - DESIGN				
55340 - PERMITS				
55350 - SPECIAL STUDIES				
55360 - EASEMENT PLATS				
55370 - LEGAL FEES				
55380 - ACQUISITION SERVICES				
55390 - COMPENSATION				
55400 - APPRAISAL				
55410 - CONDEMNATION				
55420 - CONSTRUCTION	\$1,375,000.00			\$1,375,000.00
55430 - CONST. CONTRACT ADM.				
55440 - TESTING	\$2,000.00			\$2,000.00
55450 - SURVEY - ASBUILT				
TOTAL AMOUNT	\$1,377,000.00	\$0.00	\$0.00	\$1,377,000.00

ENGINEER: MSD	DP	ESTIMATED BUDGETS - FY '18 -'26		
R.O.W. ACQUISITION:	# PLATS: [0]	FY 17-18	\$0.00	
CONTRACTOR:		FY 18-19	\$0.00	
CONSTRUCTION ADM: MSD		FY 19-20	\$0.00	
INSPECTION: MSD		FY 20-21	\$0.00	
		FY 21-22	\$0.00	
		FY 22-23	\$0.00	
PROJECT DESCRIPTION: This is a trenchless technology project that includes lining substandard sewer lines with either CIPP or Fold and Form pipe. Existing manholes will be repaired or replaced as part of this work.		FY 23-24	\$0.00	
		FY 24-25	\$0.00	
		FY 25-26	\$0.00	

SPECIAL PROJECT NOTES:

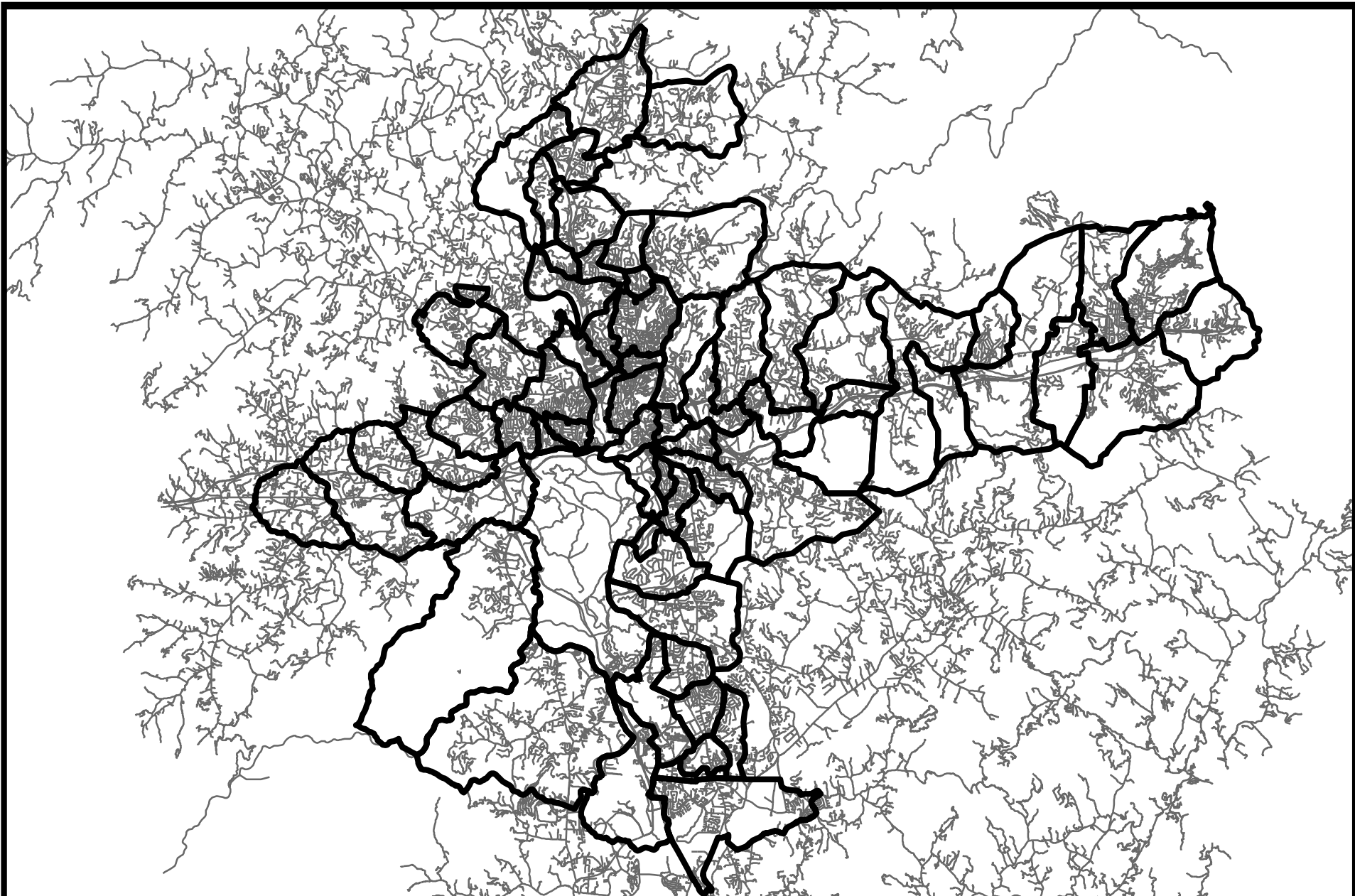

**Lining Contract No. 8
Project No. 2015218**

NOT TO SCALE



METROPOLITAN SEWERAGE DISTRICT
of
BUNCOMBE COUNTY, NORTH CAROLINA

Budget Map

Metropolitan Sewerage District of Buncombe County

BOARD ACTION ITEM

BOARD MEETING DATE: January 18, 2017

SUBMITTED BY: Tom Hartye, P.E. - General Manager

REVIEWED BY: Forrest Westall, P.E. - MSD Engineer of Record

PREPARED BY: Ed Bradford, P.E. - Director of Engineering
Hunter Carson, P.E. - Project Manager

SUBJECT: Consideration of Bids: Plant Headworks Improvements Project, MSD Project No. 2015004

BACKGROUND: The Plant Headworks Project is the first project recommended by the District's most recent update to the Plant Facility Plan. It will significantly improve the performance of the initial solids removal processes at the very head of the plant, and will help downstream processes perform better and last longer. This project is the first essential step to achieving an overall plant upgrade which will occur over future years.

The project is comprised of replacement bar screens at the head of the plant, a new fine screen and grit removal facility, as well as a surge system for wet-weather storm events over 65 mgd. Construction is expected to begin by Spring 2017, and will last approximately 18 months.

Five bids were received on December 22, 2016 for this contract in the following amounts:

<u>Contractor</u>	<u>Bid Amount</u>
1) State Utility Contractors, Inc.	\$10,680,000.00
2) Adams Robinson Enterprises, Inc.	\$ 9,847,000.00
3) Shook Construction Co., Inc.	\$ 9,604,347.00
4) Wharton-Smith, Inc.	\$ 9,138,577.00
5) Judy Construction Company	\$ 8,377,000.10

The apparent low bidder is Judy Construction Co. of Cynthiana, Kentucky with a bid amount of \$8,377,000.10. Judy Construction has not performed previous work for the District; however, HDR (the District's consulting engineer for this project) has had significant positive experience with Judy Construction, and recommends award to them.

Staff also performed a supplemental reference check, which resulted in positive comments about Judy Construction from the three organizations that were contacted.

Please refer to the attached documentation for further details, including HDR's recommendation letter and the staff reference check.

FISCAL IMPACT: The construction budget for this project (over Fiscal Years 2017 and 2018 combined) totals \$10,328,000.00.

STAFF RECOMMENDATION: Staff recommends award of this contract to Judy Construction Company in the amount of \$8,377,000.10, subject to review and approval by District Counsel.



Plant Aerial Photo showing Project Areas

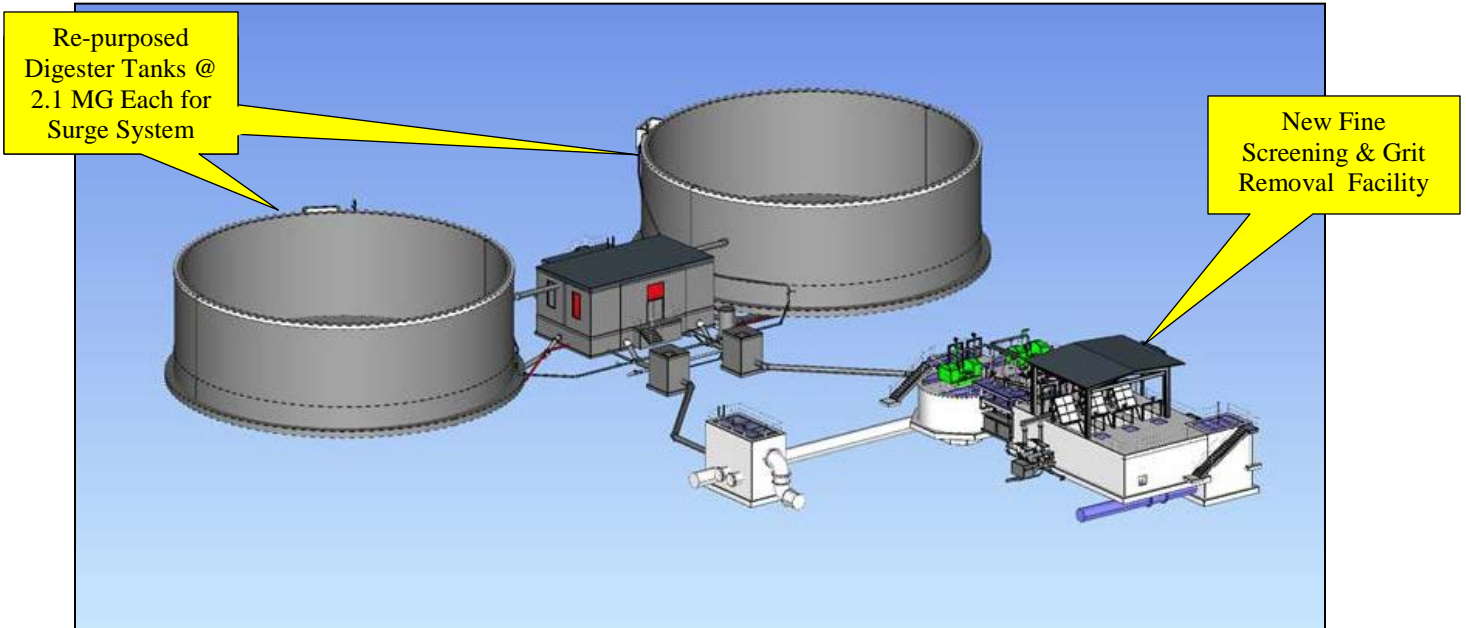

New Facilities, shown in Perspective

**METROPOLITAN SEWERAGE DISTRICT OF
BUNCOMBE COUNTY, NORTH CAROLINA**

**PLANT HEADWORKS IMPROVEMENTS
PROJECT NO. 2015004**

**BID TABULATION
December 22, 2016**

BIDDER	BID BOND	BID FORMS	TOTAL BID AMOUNT
State Utility Contractors, Inc. Monroe, NC	5%	Yes	\$10,680,000.00
Adams Robinson Enterprises, Inc. Dayton, OH	5%	Yes	\$9,847,000.00
Shook Construction Company, Inc. Apex, NC	5%	Yes	\$9,604,347.00
Wharton-Smith, Inc. Sanford, FL	5%	Yes	\$9,138,577.00
Judy Construction Company Cynthiana, KY	5%	Yes	(*) \$8,377,000.10

APPARENT LOW BIDDER

(*) Indicates correction in bidder's bid amount.

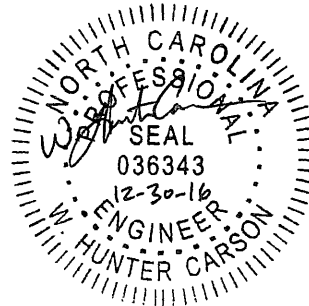

W. Hunter Carson, P.E.
Project Manager
Metropolitan Sewerage District of
Buncombe County, North Carolina

This is to certify that the bids tabulated herein were publicly opened and read aloud at 2:00 p.m. on the 22nd day of December, 2016, in the W.H. Mull Building at the Metropolitan Sewerage District of Buncombe County, Asheville, North Carolina, and that said bids were accompanied by acceptable bidders bonds in the amount of 5% of the bid.



January 6, 2017

Mr. W. Hunter Carson, PE
Project Manager
Metropolitan Sewerage District of Buncombe County
2028 Riverside Drive
Asheville, NC 28804

Re: MSD Plant Headworks Improvements Project
Recommendation of Project Award

Dear Mr. Carson,

We have evaluated the bids received on Thursday, December 22, 2016, for the MSD Plant Headworks Improvements project. Five bids were received by MSD as shown below.

Bidder	Total Base Bid
Judy Construction, Inc.	\$8,377,000.10
Wharton Smith, Inc.	\$9,138,577.00
Shook Construction	\$9,604,347.00
Adams Robinson Enterprises	\$9,847,000.00
State Utility Contractors, Inc.	\$10,680,000.00

Based upon our evaluation of the qualifications, references, experience, reputation and financial condition of Judy Construction, Inc., and its surety, we recommend award for construction of the Plant Headworks Improvements project to this contractor in the amount of \$8,377,000.10. HDR has worked with Judy Construction, Inc., based out of our Louisville and Lexington, KY offices on many different projects over the past 17 years. They have successfully constructed more than 15 treatment plant projects with us ranging in size from around \$5 million to over \$30 million in construction cost.

A Deductive Alternate bid item was utilized with the intent to increase competition for the influent screens due to a patented overflow mechanism that not all manufacturers could provide. Due to the simplicity of this device and reduced maintenance associated with it, HDR recommends accepting the Deductive Alternate for the amount of \$5,000.

If you have any questions or require any additional information, please contact us.

Sincerely,
HDR Engineering, Inc. of the Carolinas

Brian R. Thorsvold, PE
Project Manager

Plant Headworks Improvements

MSD Project No. 2015004

Supplemental Reference Check for Judy Construction Company

January 2017

Louisville & Jefferson County MSD, KY

3.5MG Surge Basin and New Pump Station (2016) - \$11.5M

Steven Leong (MSD Project Administrator) stated that Louisville & Jefferson County MSD recently completed a new 3.5MG surge basin and pump station and had a “very good experience” with Judy Construction. L&J County MSD has done several design-build projects with Judy Construction, and is currently in the midst of a \$30-40M project with them. Mr. Leong stated that there were approximately \$500k in change orders on the project, but they were all Owner requests or design modifications. Mr. Leong would highly recommend Judy Construction.

Glasgow Water Company, KY

Storm Surge and Circular Clarifier Improvements (2015) - \$10.8M

Clint Harbison (Glasgow Water Engineering Manager) stated that they “had a positive experience” with Judy Construction. He said that Judy is one of the largest plant contractors in Tennessee and Kentucky, and that they specialize in water and wastewater plant work. Mr. Harbison stated that Judy Construction was very mindful when it came to MOPO, and that there “was a lot to work around while keeping all the processes going”. Mr. Harbison said that Judy Construction was not quick to ask for change orders, and that most change orders on the job were Owner-requested. Judy Construction remained on schedule and completed the project on time. Glasgow Water Company had completed one previous project with Judy Construction, but it was in the late 1990s. Mr. Harbison would recommend working with Judy Construction.

City of Pigeon Forge, TN

New 6mgd Wastewater Treatment Plant (2015) - \$31M

Mark Miller (Pigeon Forge Public Works Director) stated that they had a very good experience with Judy Construction. The new 6mgd wastewater plant was constructed under budget and completed ahead of schedule. The project had 15 bidders and Mr. Miller was pleased that Judy won the bid based on feedback he had received. Mr. Miller has been the Public Works Director for many years and has never heard any negative feedback about Judy Construction. Furthermore, many equipment vendors provided good referrals prior to his project. Mr. Miller said that Judy Construction had a great superintendent who maintained good working relationships through the length of the project. Mr. Miller would recommend Judy Construction.

**Metropolitan Sewerage District of Buncombe County, North Carolina
CAPITAL IMPROVEMENT PROGRAM**

BUDGET DATA SHEET - FY 2016 - 2017

PROJECT: Plant Headworks Improvements	LOCATION: MSD-Treatment Plant
TYPE: Treatment Plant	PIPE RATING: N/A
PROJECT NO.: 2015004	TOTAL LF: 0
PROJECT BUDGET: \$11,538,575.00	PROJECT ORIGIN: Facilities Plan Update - HDR

DESCRIPTION	ESTIMATED PROJECT COST	TOTAL EXPENDS THRU 12/31/15	EST. COST JAN - JUNE 2016	EST. BUDGET FY 16-17
55310 - PRELIM. ENGINEERING				
55320 - SURVEY - DESIGN	\$2,275.00	\$2,250.00	\$25.00	
55330 - DESIGN	\$800,000.00	\$207,967.00	\$478,033.00	\$114,000.00
55340 - PERMITS	\$32,000.00			\$32,000.00
55350 - SPECIAL STUDIES	\$8,300.00	\$7,848.00	\$452.00	
55360 - EASEMENT PLATS				
55370 - LEGAL FEES				
55380 - ACQUISITION SERVICES				
55390 - COMPENSATION				
55400 - APPRAISAL				
55410 - CONDEMNATION				
55420 - CONSTRUCTION	\$10,328,000.00			\$5,164,000.00
55430 - CONST. CONTRACT ADM.	\$368,000.00			\$147,000.00
55440 - TESTING				
55450 - SURVEY - ASBUILT				
TOTAL AMOUNT	\$11,538,575.00	\$218,065.00	\$478,510.00	\$5,457,000.00

ENGINEER: TBD	HC	ESTIMATED BUDGETS - FY '18 -'26	
R.O.W. ACQUISITION: N/A	# PLATS: [0]	FY 17-18	\$5,385,000.00
CONTRACTOR:		FY 18-19	\$0.00
CONSTRUCTION ADM.: TBD		FY 19-20	\$0.00
INSPECTION: TBD		FY 20-21	\$0.00
		FY 21-22	\$0.00
PROJECT DESCRIPTION: This project is a recommendation from the Facilities Plan Update, a WRF master planning document completed by HDR in April 2015. This project consists of a new influent screening facility, new grit removal system, fine screening facility, and surge/equalization basins and pumping station at the French Broad River WRF. The upgrades will improve downstream water quality and shave peak flows into the WRF.		FY 22-23	\$0.00
		FY 23-24	\$0.00
		FY 24-25	\$0.00
		FY 25-26	\$0.00

SPECIAL PROJECT NOTES:



**Plant Headworks Improvements
Project No. 2015004**

NOT TO SCALE



METROPOLITAN SEWERAGE DISTRICT
of
BUNCOMBE COUNTY, NORTH CAROLINA

Budget Map

Metropolitan Sewerage District of Buncombe County

BOARD ACTION ITEM

BOARD MEETING DATE: January 18, 2017

SUBMITTED BY: Tom Hartye, P.E. - General Manager

PREPARED BY: Ed Bradford, P.E. - Director of Engineering
Hunter Carson, P.E. - Project Manager

SUBJECT: Consideration of Construction Administration Contract: Plant Headworks Improvements Project, MSD Project No. 2015004

BACKGROUND: HDR is the District's consulting engineer for the Plant Headworks Project. They were awarded the design contract at the July 15, 2015 regular board meeting, and have performed their tasks well.

The project is now ready for the construction phase. District construction staff will perform most of the daily on-site inspection work; however, HDR will still be needed to perform specialized tasks and services. These include review/approval of all construction submittals; attendance at monthly progress meetings; periodic site inspections; technical assistance with all RFIs, Change Orders, and WCDs; and producing complete record drawings after project completion.

Given their excellent performance and experience with this project, HDR is the most qualified consultant to perform the construction administration services. They submitted a lump sum fee of \$270,416.00 for CA Services over the estimated 18-month construction period. This fee equates to 3.2% of the construction contract, which staff believes is a fair price.

Please refer to the attached documentation for further details.

FISCAL IMPACT: The construction administration budget for this project (over Fiscal Years 2017 and 2018 combined) totals \$368,000.00.

STAFF RECOMMENDATION: Staff recommends award of the Construction Administration Contract to HDR Engineering in the amount of \$270,416.00, subject to review and approval by District Counsel.

Interoffice Memorandum

TO: Tom Hartye, General Manager

FROM: Ed Bradford, Director of Engineering
Hunter Carson, Project Manager

DATE: January 4, 2017

RE: Plant Headworks Improvements – HDR Construction Administration Services
Contract, MSD Project No. 2015004

Having successfully bid the Plant Headworks Improvements project on December 22, 2016, HDR has completed all tasks associated with the engineering design services contract awarded to them in July 2015. As the Plant Headworks project moves towards the construction phase, MSD staff requested that HDR provide a scope and fee for Construction Administration services. Services include attendance at monthly progress meetings, periodic site inspection (MSD staff will perform full-time inspection), submittal review, technical assistance with RFIs, Change Orders, and WCDs, and development of record drawings. Given HDR's design history and experience with this project, as well as their detailed knowledge of the French Broad River WRF, HDR is the most qualified consultant to perform Construction Administration tasks for this project.

HDR submitted a lump sum fee of \$270,416.00 for CA Services over the estimated 18-month construction period. This fee equates to 3.2% of the construction contract which MSD staff believes is a fair price. A breakdown of this fee, as well as full description of tasks included can be reviewed in the attached Scope of Services.

The total project budget for CA Services is \$368,000.00, with \$147,000.00 allotted for Fiscal Year 2016-17 and the remainder in Fiscal Year 2017-18.

Staff recommends that this contract be awarded to HDR in the amount of \$270,146.00, subject to MSD legal counsel's review and approval.

**MSD - French Broad River WRF
Plant Headworks Improvements Project
Construction Phase Services**

Task No.	Task Description Hourly rate	Manhour Forecast (Hrs)													Total Hours	Task Fee	Expenses			Total Expenses	Total Fee
		TA/QC 215	PM 205	PE 125	Sr. Str 190	SE 120	EE 155	I&C 155	Civil 155	S CAD 140	CAD 125	COST 185	ADM 85	ACCT 100			Travel	Repro/ supplies	Tech		
100	Submittal Reviews		40	120	16	100	80	24	24				110	18	532	\$69,230		500	1,974	\$2,474	\$71,704
200	Respond to RFIs		40	80	24	24	32	16	8	2	4		50		280	\$39,350		500	1,039	\$1,539	\$40,889
300	Change Requests / Field Orders		40	80	16	24	42	8	8	4	16	8	16		262	\$38,510		500	972	\$1,472	\$39,982
400	Site Visits / Meetings / Conference Calls	12	225	98	48		48	24	16				12		483	\$84,735	7,000	1,000	1,792	\$9,792	\$94,527
500	Record Drawings		12	24	4	8	16	8	8	20	40		4		144	\$20,280		2,500	534	\$3,034	\$23,314
	TOTAL	12	357	402	108	156	218	80	64	26	60	8	192	18	1,701	\$252,105	\$7,000	\$5,000	\$6,311	\$18,311	\$270,416

**Metropolitan Sewerage District of Buncombe County, North Carolina
CAPITAL IMPROVEMENT PROGRAM**

BUDGET DATA SHEET - FY 2016 - 2017

PROJECT:	Plant Headworks Improvements	LOCATION:	MSD-Treatment Plant
TYPE:	Treatment Plant	PIPE RATING:	N/A
PROJECT NO.	2015004	TOTAL LF:	0
PROJECT BUDGET:	\$11,538,575.00	PROJECT ORIGIN:	Facilities Plan Update - HDR

DESCRIPTION	ESTIMATED PROJECT COST	TOTAL EXPENDS THRU 12/31/15	EST. COST JAN - JUNE 2016	EST. BUDGET FY 16-17
55310 - PRELIM. ENGINEERING				
55320 - SURVEY - DESIGN	\$2,275.00	\$2,250.00	\$25.00	
55330 - DESIGN	\$800,000.00	\$207,967.00	\$478,033.00	\$114,000.00
55340 - PERMITS	\$32,000.00			\$32,000.00
55350 - SPECIAL STUDIES	\$8,300.00	\$7,848.00	\$452.00	
55360 - EASEMENT PLATS				
55370 - LEGAL FEES				
55380 - ACQUISITION SERVICES				
55390 - COMPENSATION				
55400 - APPRAISAL				
55410 - CONDEMNATION				
55420 - CONSTRUCTION	\$10,328,000.00			\$5,164,000.00
55430 - CONST. CONTRACT ADM.	\$368,000.00			\$147,000.00
55440 - TESTING				
55450 - SURVEY - ASBUILT				
TOTAL AMOUNT	\$11,538,575.00	\$218,065.00	\$478,510.00	\$5,457,000.00

ENGINEER:	TBD	HC	ESTIMATED BUDGETS - FY '18 -'26	
R.O.W. ACQUISITION:	N/A	# PLATS: [0]	FY 17-18	\$5,385,000.00
CONTRACTOR:			FY 18-19	\$0.00
CONSTRUCTION ADM.:	TBD		FY 19-20	\$0.00
INSPECTION:	TBD		FY 20-21	\$0.00
			FY 21-22	\$0.00
PROJECT DESCRIPTION: This project is a recommendation from the Facilities Plan Update, a WRF master planning document completed by HDR in April 2015. This project consists of a new influent screening facility, new grit removal system, fine screening facility, and surge/equalization basins and pumping station at the French Broad River WRF. The upgrades will improve downstream water quality and shave peak flows into the WRF.			FY 22-23	\$0.00
			FY 23-24	\$0.00
			FY 24-25	\$0.00
			FY 25-26	\$0.00

SPECIAL PROJECT NOTES:



**Plant Headworks Improvements
Project No. 2015004**

NOT TO SCALE



METROPOLITAN SEWERAGE DISTRICT
of
BUNCOMBE COUNTY, NORTH CAROLINA

Budget Map

Metropolitan Sewerage District of Buncombe County

Board Action Item

BOARD MEETING DATE: January 18, 2017

SUBMITTED BY: Tom Hartye, P.E. - General Manager

REVIEWED BY: Ed Bradford, P.E. - Engineering Director

PREPARED BY: Kevin Johnson, P.E. - Planning & Development Manager

SUBJECT: Acceptance of Developer Constructed Sewer System for the Amboy Overlook Phase 1, MSD Project No. 2014136

BACKGROUND: This project is located inside the District boundary off Amboy Road in the City of Asheville. The developer for this project is Jay Fiano.

The project included extending approximately 388 linear feet of 8-inch public gravity sewer to serve the new subdivision.

A wastewater allocation was issued in the amount of 2,400 GPD for this phase (8 units) of the single family residential development. The estimated cost of the sewer construction is \$50,000.00.

All MSD requirements have been met.

STAFF RECOMMENDATION: Staff recommends acceptance of this developer constructed sewer system.

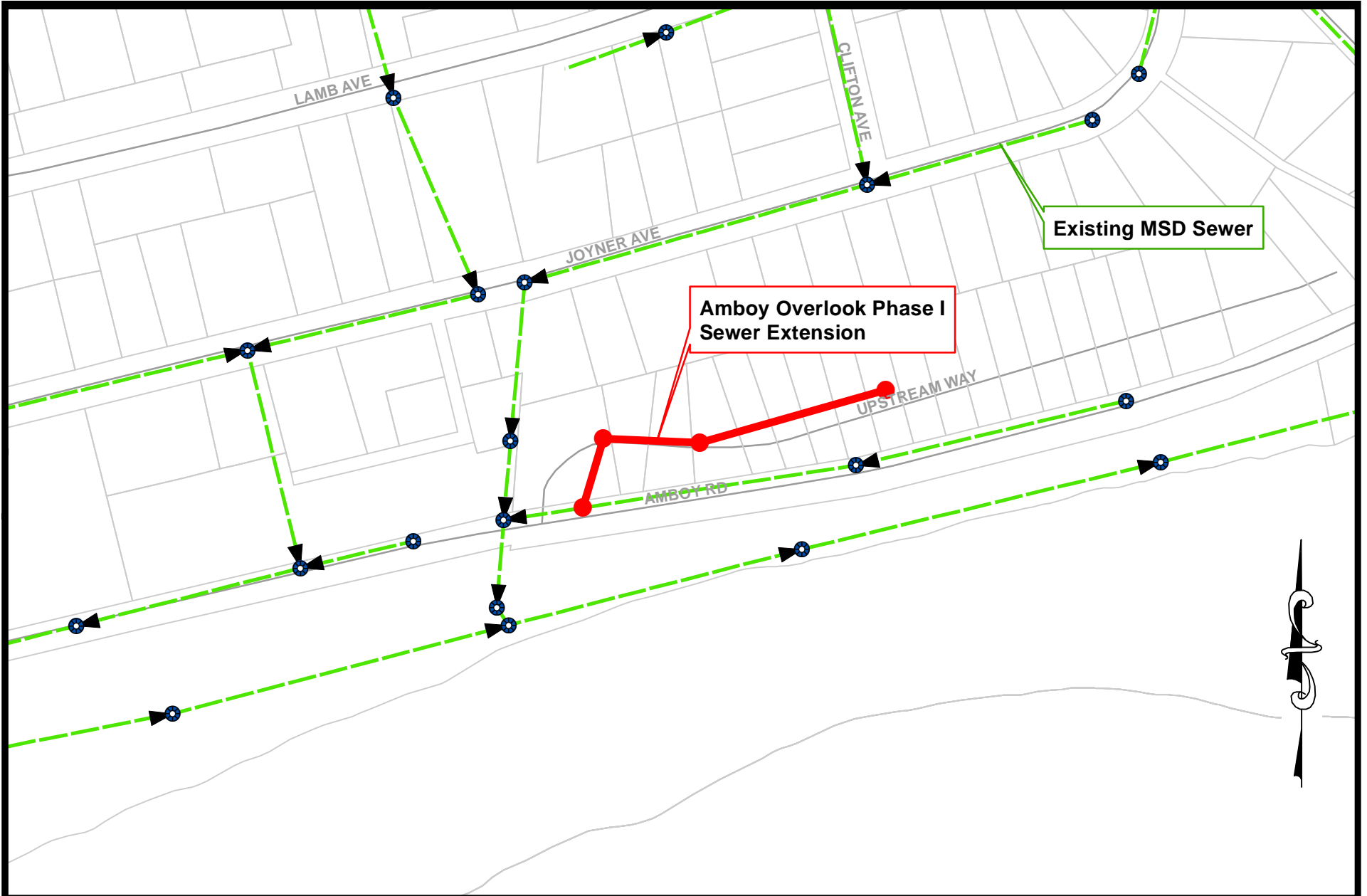

MSD
Engineering Division

Amboy Overlook Phase I Sewer Extension
MSD Project # 2014136
Metropolitan Sewerage District of Buncombe County

01/05/2017

Metropolitan Sewerage District of Buncombe County

Board Action Item

BOARD MEETING DATE: January 18, 2017

SUBMITTED BY: Tom Hartye, P.E. - General Manager

REVIEWED BY: Ed Bradford, P.E. - Engineering Director

PREPARED BY: Kevin Johnson, P.E. - Planning & Development Manager

SUBJECT: Acceptance of Developer Constructed Sewer System for the Ingles No. 134 – Sand Hill Road, MSD Project No. 2014024

BACKGROUND: This project is located inside the District boundary off Sand Hill Road in Buncombe County. The developer for this project is Preston Kendall of Ingles Markets, Inc.

The project included extending approximately 1,066 linear feet of 8-inch public gravity sewer to serve the development.

A wastewater allocation was issued in the amount of 3,000 GPD to serve the commercial development. The estimated cost of the sewer construction is \$150,000.00.

All MSD requirements have been met.

STAFF RECOMMENDATION: Staff recommends acceptance of this developer constructed sewer system.

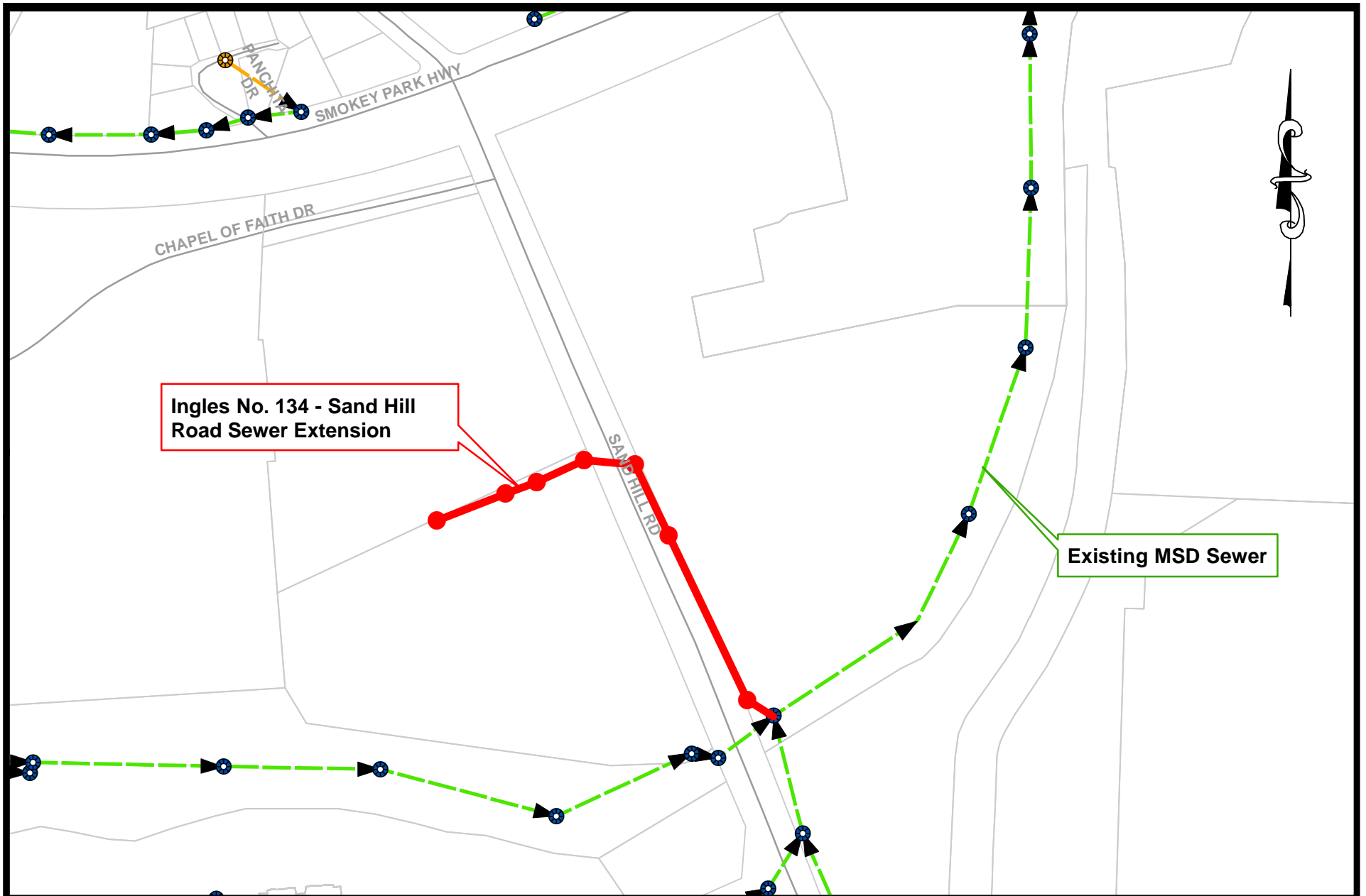

Ingles No. 134 - Sand Hill Road Sewer Extension

Existing MSD Sewer



MSD
Engineering Division

**Ingles No. 134 - Sand Hill Road Sewer Extension
MSD Project # 2014024**

Metropolitan Sewerage District of Buncombe County

01/05/2017

Metropolitan Sewerage District of Buncombe County

Board Action Item

BOARD MEETING DATE: January 18, 2017

SUBMITTED BY: Tom Hartye, P.E. - General Manager

REVIEWED BY: Ed Bradford, P.E. - Engineering Director

PREPARED BY: Kevin Johnson, P.E. - Planning & Development Manager

SUBJECT: Acceptance of Developer Constructed Sewer System for Vance Place Drive, MSD Project No. 2014084

BACKGROUND: This project is located inside the District boundary off S. Charlotte Street in the City of Asheville. The developer for this project is Bruce Hankerson of Trinity Cove, LLC.

The project included relocating approximately 395 linear feet of 8-inch public gravity sewer and abandoning approximately 171 LF of public gravity sewer to serve the new subdivision.

A wastewater allocation was issued in the amount of 1,800 GPD to serve the six (6) unit single family residential development. The estimated cost of the sewer construction is \$68,818.00.

All MSD requirements have been met.

STAFF RECOMMENDATION: Staff recommends acceptance of this developer constructed sewer system.

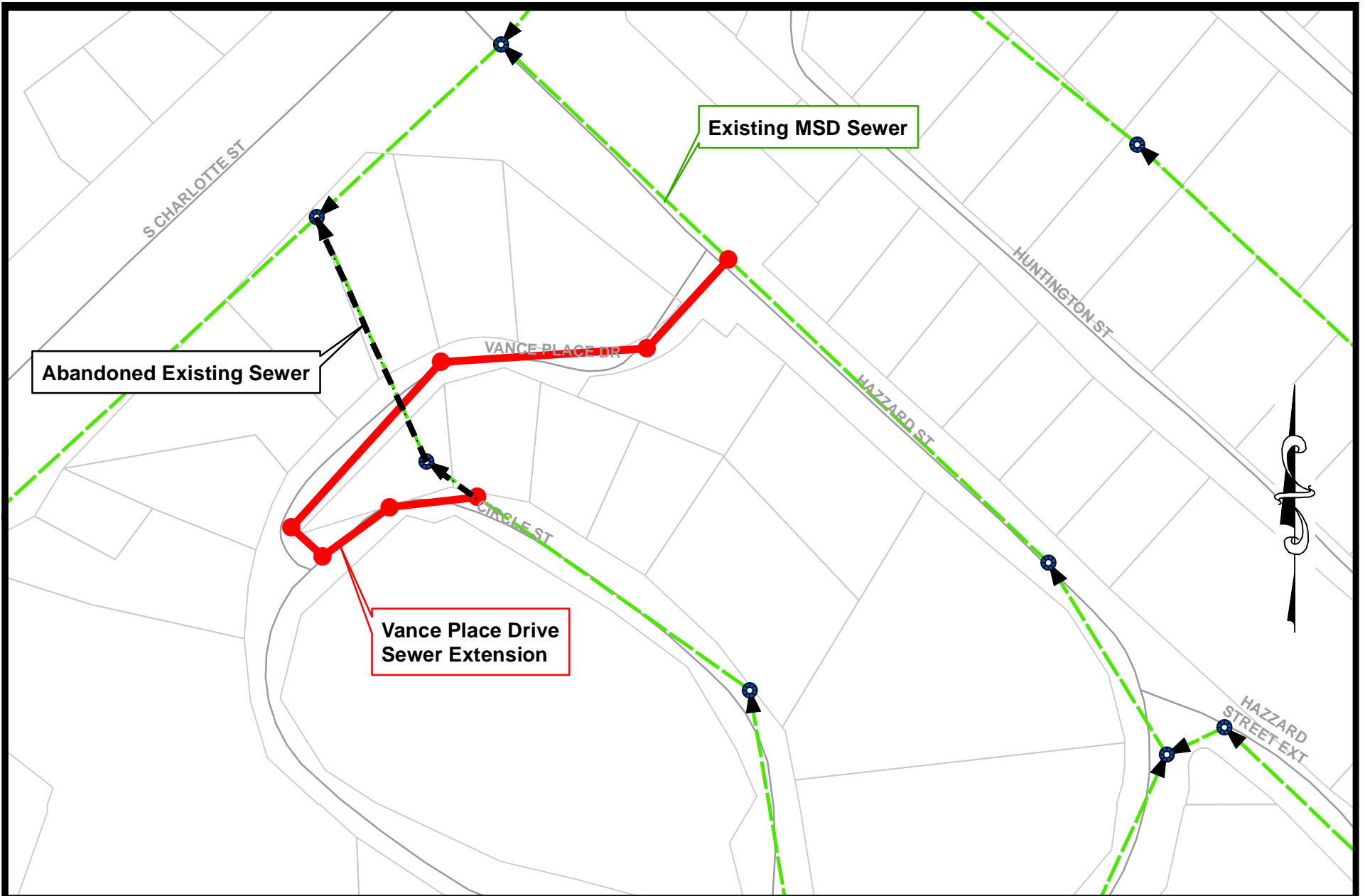

MSD
Engineering Division

**Vance Place Dr. Sewer Extension
MSD Project # 2014084**

Metropolitan Sewerage District of Buncombe County

01/05/2017

Metropolitan Sewerage District of Buncombe County

Board Action Item

BOARD MEETING DATE: January 18, 2017

SUBMITTED BY: Tom Hartye, P.E. - General Manager

REVIEWED BY: Ed Bradford, P.E. - Engineering Director

PREPARED BY: Kevin Johnson, P.E. - Planning & Development Manager

SUBJECT: Acceptance of Developer Constructed Sewer System for Woodcrest at Biltmore Terrace, MSD Project No. 2015063

BACKGROUND: This project is located inside the District boundary off Lamar Avenue in the City of Asheville. The developer for this project is Kyle Gilliland of Highland Property Group, LLC.

The project included extending approximately 203 linear feet of 8-inch public gravity sewer to serve the new subdivision.

A wastewater allocation was issued in the amount of 2,400 GPD to serve the eight (8) unit single family residential development. The estimated cost of the sewer construction is \$20,000.00.

All MSD requirements have been met.

STAFF RECOMMENDATION: Staff recommends acceptance of this developer constructed sewer system.

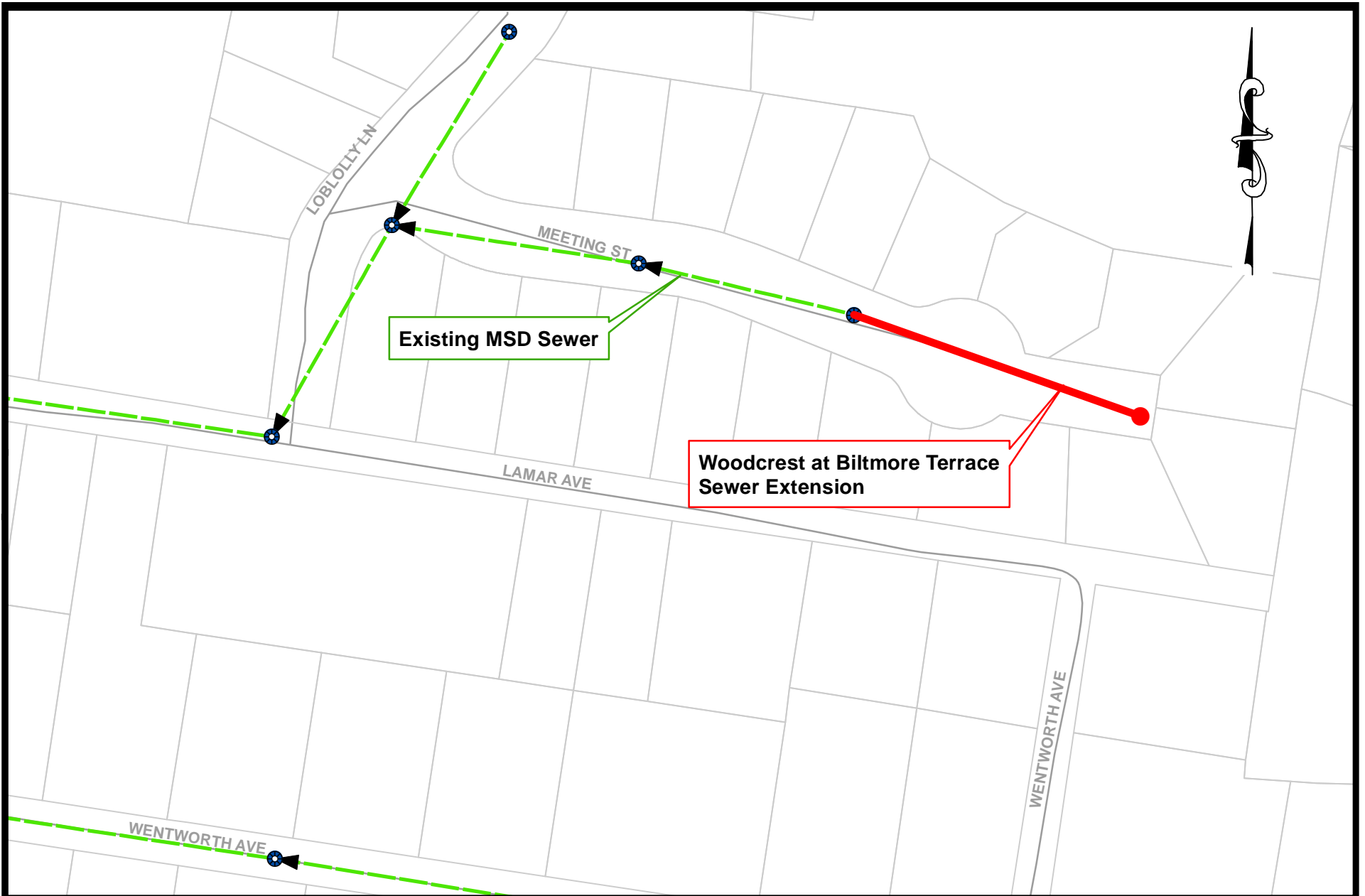

MSD
Engineering Division

Woodcrest at Biltmore Terrace Sewer Extension MSD Project # 2015063

Metropolitan Sewerage District of Buncombe County

01/05/2017

Metropolitan Sewerage District of Buncombe County

BOARD INFORMATIONAL ITEM

Meeting Date: January 18, 2017
Submitted By: Thomas E. Hartye, PE., General Manager
Prepared By: W. Scott Powell, CLGFO, Director of Finance
 Cheryl Rice, Accounting Manager
Subject: Cash Commitment/Investment Report-Month Ended November 30, 2016

Background

Each month, staff presents to the Board an investment report for all monies in bank accounts and specific investment instruments. The total investments as of November 30, 2016 were \$49,557,559. The detailed listing of accounts is available upon request. The average rate of return for all investments is 0.506%. These investments comply with North Carolina General Statutes, Board written investment policies, and the District's Bond Order.

The attached investment report represents cash and cash equivalents as of November 30, 2016 do not reflect contractual commitments or encumbrances against said funds. Shown below are the total investments as of November 30, 2016 reduced by contractual commitments, bond funds, and District reserve funds. The balance available for future capital outlay is \$9,730,373.

Total Cash & Investments as of 11/30/2016		49,557,559
Less:		
Budgeted Commitments (Required to pay remaining FY17 budgeted expenditures from unrestricted cash)		
Construction Funds	(17,420,604)	
Operations & Maintenance Fund	(9,853,673)	(27,274,277)
Bond Restricted Funds		
Bond Service (Funds held by trustee):		
Funds in Principal & Interest Accounts	(25,651)	
FY17 Principal & Interest Due	(7,494,510)	(7,520,161)
District Reserve Funds		
Fleet Replacement	(747,437)	
Pump Replacement	(70,959)	
WWTP Replacement	(440,923)	
Maintenance Reserve	(958,353)	(2,217,672)
District Insurance Funds		
General Liability	(351,020)	
Worker's Compensation	(139,272)	
Post-Retirement Benefit	(1,577,209)	
Self-Funded Employee Medical	(747,575)	(2,815,076)
Designated for Capital Outlay		9,730,373

Staff Recommendation

None. Information Only.

Action Taken

Motion by:

to

Approve
Table

Disapprove

Send to Committee

Second by:

Other:

Follow-up Required:

Person Required:

Deadline:

Metropolitan Sewerage District of Buncombe County
Investment Portfolio

	Operating Checking Accounts	Gov't Advantage Money Market	NCCMT (Money Market)	Certificate of Deposit	Commercial Paper	Municipal Bonds	Cash Reserve	Gov't Agencies & Treasuries	Total
Held with Bond Trustee	\$ 4,725,158	\$ 46,671	\$ 25,651	\$ -	\$ -	\$ -	\$ -	\$ -	\$ 25,651
Held by MSD	\$ 4,725,158	\$ 46,671	\$ 19,675,688	\$ -	\$ 7,984,391	\$ 10,600,000	\$ -	\$ 6,500,000	\$ 49,531,908
	\$ 4,725,158	\$ 46,671	\$ 19,701,339	\$ -	\$ 7,984,391	\$ 10,600,000	\$ -	\$ 6,500,000	\$ 49,557,559

Investment Policy Asset Allocation		
	Maximum Percent	Actual Percent
U.S. Government Treasuries,		
Agencies and Instrumentalities	100%	13.12%
Bankers' Acceptances	20%	0.00%
Certificates of Deposit	100%	0.00%
Commercial Paper	20%	16.11%
Municipal Bonds	100%	21.40%
North Carolina Capital Management Trust	100%	39.75%
Checking Accounts:		
Operating Checking Accounts	100%	9.53%
Gov't Advantage Money Market		0.09%

No significant changes in the investment portfolio as to makeup or total amount.

The District's YTM of .82% is exceeding the YTM benchmarks of the 6 month T-Bill and NCCMT Cash Portfolio.

All funds invested in CD's, operating checking accounts, Gov't Advantage money market are fully collateralized with the State Treasurer.

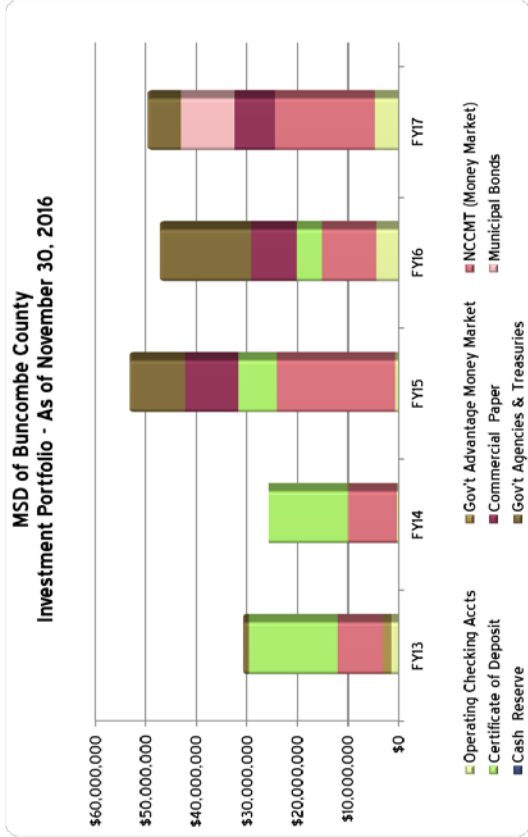
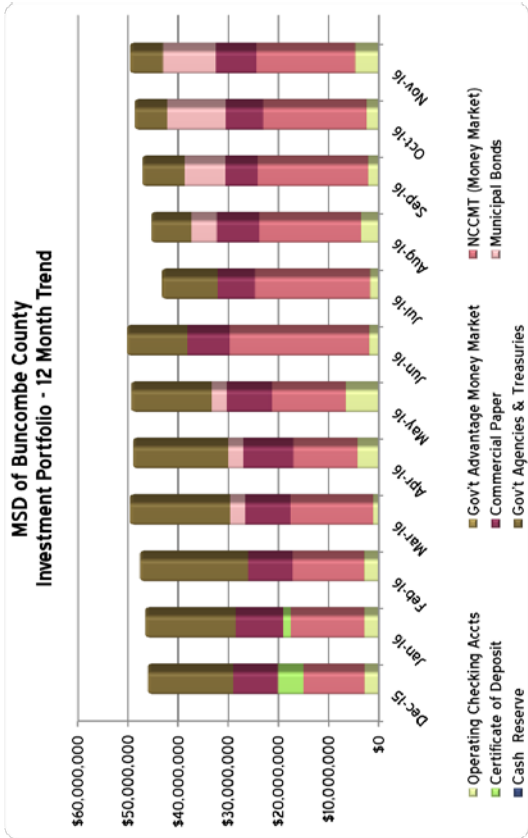

Board Meeting: January 18, 2017

Subject: Cash Commitment/Investment Report-Month Ended November 30, 2016

Page -3-

**METROPOLITAN SEWERAGE DISTRICT
INVESTMENT MANAGERS' REPORT
At November 30, 2016**

Summary of Asset Transactions

	Original Cost	Market	Interest Receivable
Beginning Balance	\$ 44,340,601	\$ 44,389,679	\$ 16,133
Capital Contributed (Withdrawn)		-	
Realized Income	18,411	18,411	(8,958)
Unrealized/Accrued Income		16,112	8,968
Ending Balance	\$ 44,359,012	\$ 44,424,202	\$ 16,242

Value and Income by Maturity

	Original Cost	Income
Cash Equivalents <91 Days	\$ 37,507,501	\$ 30,204
Securities/CD's 91 to 365 Days	1,000,000	\$ 805
Securities/CD's > 1 Year	4,500,000	\$ 3,624
Total	\$ 43,007,501	\$ 34,632

Month End Portfolio Information

Weighted Average Maturity	181
Yield to Maturity	0.82%
6 Month T-Bill Secondary Market	0.61%
NCCMT Cash Portfolio	0.29%

**Metropolitan Sewerage District
Annual Yield Comparison**

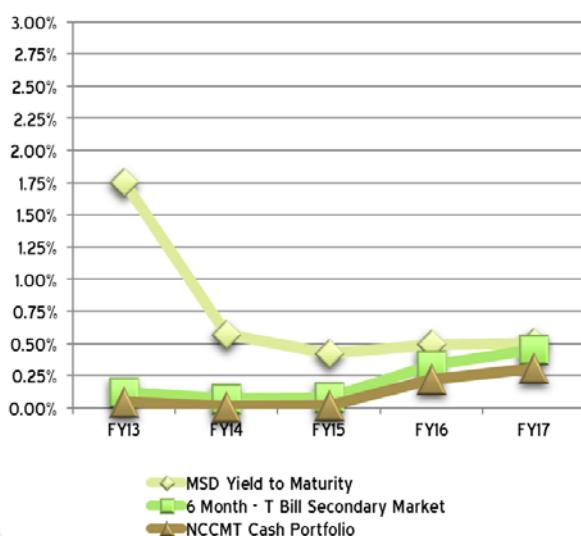

**Metropolitan Sewerage District
Yield Comparison - November 30, 2016**

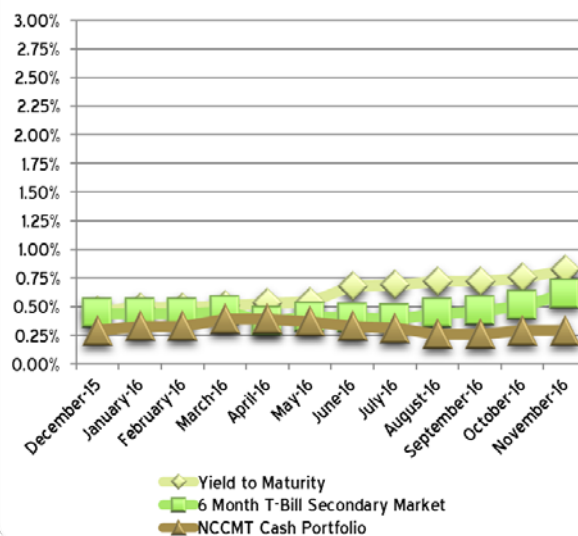

Board Meeting: January 18, 2017

Subject: Cash Commitment/Investment Report-Month Ended November 30, 2016

Page -4-

**METROPOLITAN SEWERAGE DISTRICT
ANALYSIS OF CASH RECEIPTS
As of November 30, 2016**

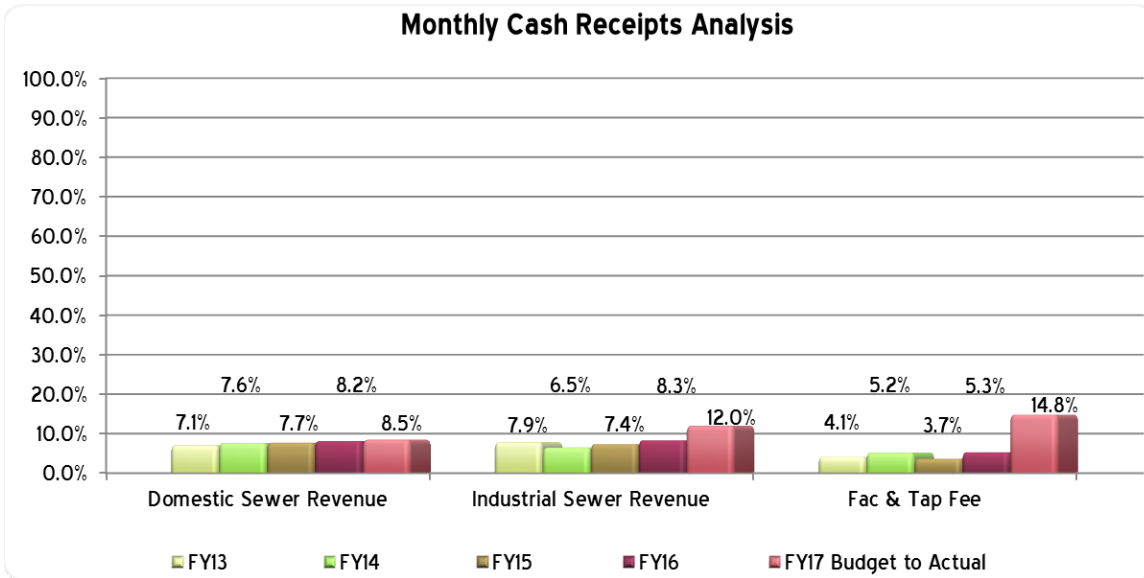

Monthly Cash Receipts Analysis:

- Monthly domestic sewer revenue is considered reasonable based on timing of cash receipts in their respective fiscal periods.
- Monthly industrial sewer revenue is reasonable based on historical trends.
- Due to the unpredictable nature of facility and tap fee revenue, staff considers facility and tap fee revenue reasonable.

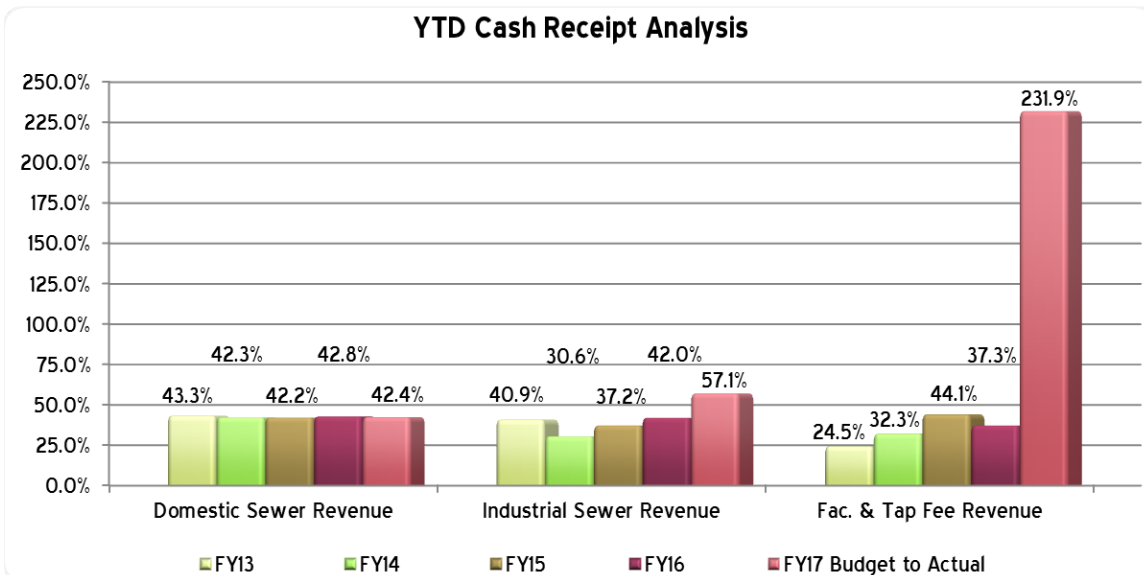

YTD Actual Revenue Analysis:

- YTD domestic sewer revenue is considered reasonable based on historical trends.
- YTD industrial sewer revenue is reasonable based on historical trends.
- Due to the unpredictable nature of facility and tap fee revenue, staff considers facility and tap fee revenue reasonable.

**METROPOLITAN SEWERAGE DISTRICT
ANALYSIS OF EXPENDITURES
As of November 30, 2016**

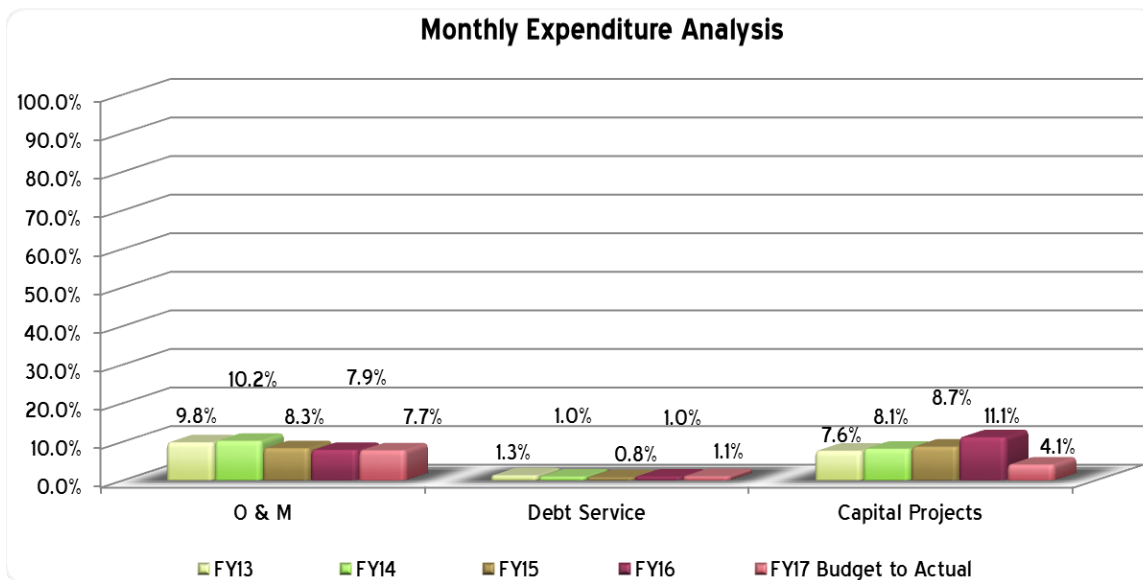

Monthly Expenditure Analysis:

- Monthly O&M expenditures are considered reasonable based on historical trends and timing of expenditures in the current year.
- Due to the nature of the variable rate bond market, monthly expenditures can vary year to year. Based on current variable interest rates, monthly debt service expenditures are considered reasonable.
- Due to nature and timing of capital projects, monthly expenditures can vary from year to year. Based on the current outstanding capital projects, monthly capital project expenditures are considered reasonable.

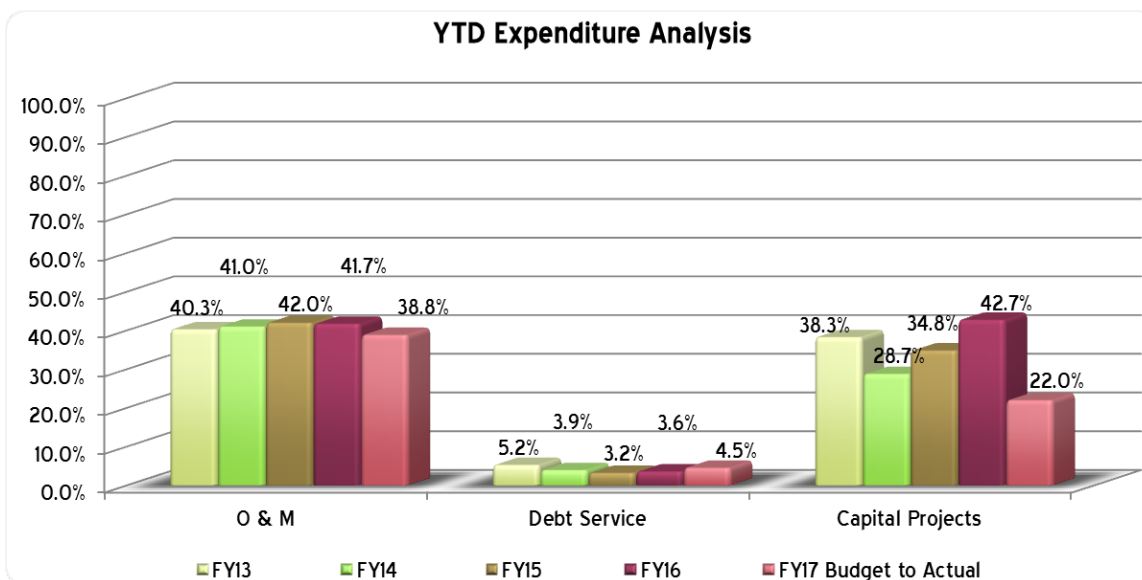

YTD Expenditure Analysis:

- YTD O&M expenditures are considered reasonable based on historical trends.
- Due to the nature of the variable rate bond market, YTD expenditures can vary year to year. Based on current variable interest rates, YTD debt service expenditures are considered reasonable.
- Due to nature and timing of capital projects, YTD expenditures can vary from year to year. Based on the current outstanding capital projects, YTD capital project expenditures are considered reasonable.

Board Meeting: January 18, 2017

Subject: Cash Commitment/Investment Report-Month Ended November 30, 2016

Page -6-

**METROPOLITAN SEWERAGE DISTRICT
VARIABLE DEBT SERVICE REPORT
As of December 31, 2016**

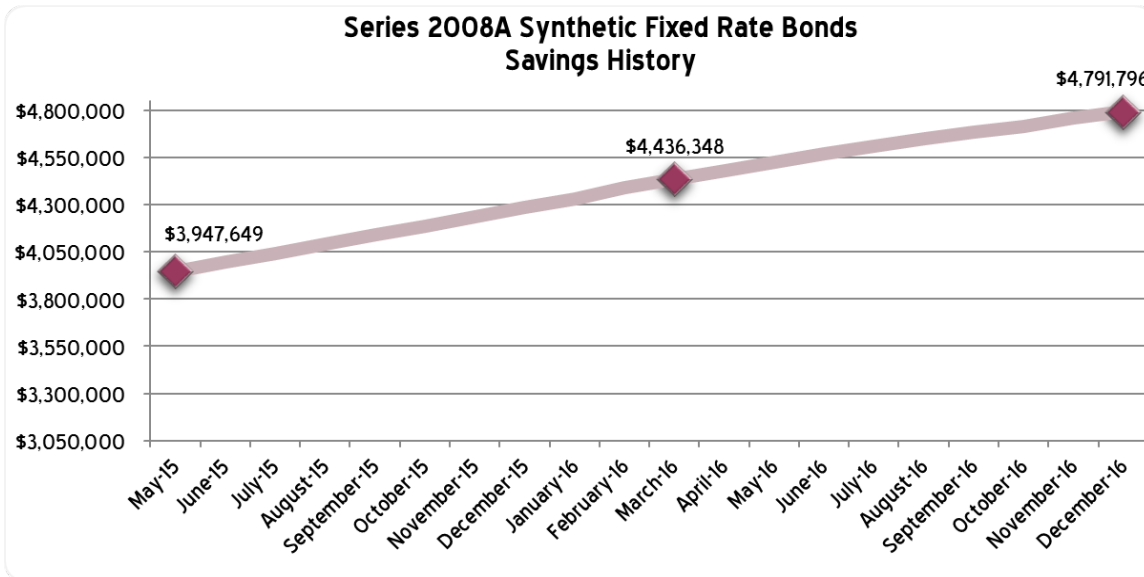
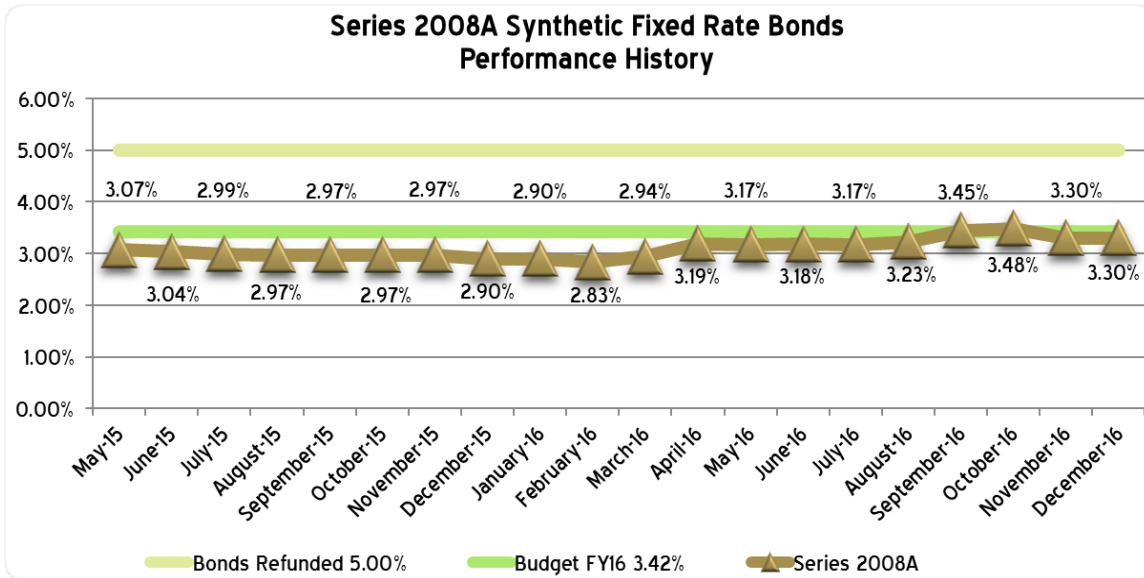

Series 2008A:

- ▶ Savings to date on the Series 2008A Synthetic Fixed Rate Bonds is \$4,791,796 as compared to 4/1/2008 fixed rate of 4.85%.
- ▶ Assuming that the rate on the Series 2008A Bonds continues at the current all-in rate of 3.9475%, MSD will achieve cash savings of \$4,670,000 over the life of the bonds.
- ▶ MSD would pay \$4,056,592 to terminate the existing Bank of America Swap Agreement.

STATUS REPORTS

MSD System Services In-House Construction

FY 16-17 PROJECTS

PROJECT NAME	LOCATION	ZIP CODE	ESTIMATED FOOTAGE	ESTIMATED PROJECT DATES	WO#	CREW	COMPLETION DATE	ACTUAL FOOTAGE	NOTES
Asheville Country Club Phase 1 B	N. Asheville	28804	1739	6/29/16 - 7/21/16	234696	631	7/21/2016	1739	complete
Asheville Country Club 6" Replacement	N. Asheville	28804	325	7/25/16 - 7/27/16	235071	631	7/27/2016	325	complete
Tanglewood Drive at Craggy Ave	W. Asheville	28803	141	7/18/16 - 7/28/16	233397	632	7/28/2016	101	complete
Graceland Place Rehabilitation	Arden	28704	120	6/27/16 - 8/2/126	234656	632	8/2/2016	120	complete
Dejeuil Drive Sewer Rehabilitation	W. Asheville (Starnes Cove)	28806	300	8/8/16 - 9/1/16	219451	632	8/15/2016	300	complete
Asheville Country Club Phase 2	N. Asheville	28804	3,900	7/28-16 - 9/28/16	225192	631	9/30/2016	3,923	complete
Lakeshore Drive	N. Asheville	28804	500	9/2/16 - 10-1/16	235169	632	10/5/2016	597	complete
Asheville Country Club Phase 1C	N. Asheville	28804	230	10/3/2016 -10/7/16	236906	631	10/6/2016	235	complete
166 S. French Broad Ave	Asheville	28803	280	10/4/16 - 10/7/16	236410	632	10/12/2016	317	complete
643 Haywood Road Emergency Sewer Rehabilitati	W. Asheville	28806	336	10/10/16 - 10/14/16	237069	632	10/20/2016	365	complete
Asheville Country Club Phase 3 (Robinhood Rd)	N. Asheville	28804	600	10/10/19 - 10/31/16	236602	631	11/16/2016	759	complete
Upper Chestnut @ Lookout Road (Ph. 1)	Woodfin	28804	800	11/07/16 - 12/30/16	210370	632	12/30/2016	787	complete
Meadowbrook Rd Rehabilitation	Black Mountain	28711	1327	11/17/16 - 1/31/17	236632	631			construction 75% complete
Chestnut @ Lookout Road Phase 2	Woodfin	28804	479	1/3/17 - 1/13/17	239165	632			construction just underway
5 Spring Cove Terr	Beaverdam	28804	375	1/13/17 - 1/31/17	233212	632			ready for construction
Buck Shoals Road	Arden	28704	350	1/13/17 - 1/31/17	239381	631			ready for construction
Spears Avenue Rehabilitation	Asheville	28801	300	2/1/17 - 2/28/17	225197	631			ready for construction
Celia Place at Bond Street	Asheville	28801	526	FY 16-17	227752	631			ready for construction
Starnes Avenue at Broadway Street	Asheville	28801	400	FY 16-17	208325	TBA			ready for construction
350 Old Haw Creek Road	Asheville	28805	1333	FY 16-17	47802	TBA			ready for construction
905 Patton Avenue	Asheville	28806	187	FY 16-17	220384	TBA			ready for construction
149 Weston Rd	Arden	28704	210	FY 16-17	225004	TBA			ready for construction
110 Beaver Drive	Woodfin	28804	425	FY 16-17	210211	TBA			ready for construction
18 Crestland Road	Asheville	28803	270	FY 16-17	46826	TBA			ready for construction
Belmont Road	W. Asheville	28806	170	FY 16-17	233437	TBA			ready for construction
304 9th Street	Black Mountain	28711	450	FY 16-17	236507	TBA			In Design
317 Barnard Road	Asheville	28804	299	FY 16-17	236089	TBA			In Design
69 Providence Road	West Asheville	28806	190	FY 16-17	231127	TBA			In Design
722 Center St	Asheville	28803	265	FY 16-17	229911	TBA			In Design
Seventh St	Black Mountain	28711	200	FY 16-17	225198	TBA			In design
School Road at Woodland	W. Asheville	28806	350	FY 16-17	224993	TBA			In design
179 Old Haw Creek Rd	Asheville	28805	760	FY 16-17	220080	TBA			In Design
Biltmore Avenue at Bryson Street	Asheville	28801	200	FY 16-17	225195	TBA			In Design
184 West Chestnut	Asheville	28801	320	FY 16-17	201957	TBA			In Design
24 Ivey Street	W Asheville	28806	850	FY 16-17	236509	TBA			In Design
15 New Jersey	Asheville	28806	250	FY 16-17	238782	TBA			In Design



CONSTRUCTION TOTALS BY DATE COMPLETED - Monthly

From 7/1/2016 to 11/30/2016

	Dig Ups	Emergency Dig Ups	Dig Up ML Ftg	Dig Up SL Ftg	Manhole Repairs	Taps Installed	ROW Ftg	IRS Rehab Ftg *	Const Rehab Ftg *	D-R Rehab Ftg *	Manhole Installs	Bursting Rehab Ftg *	Total Rehab Ftg *
July 2016	24	9	114	706	35	27	1,620	0	16	377	11	1,788	2181
August 2016	40	11	149	1,050	36	40	1,586	0	264	300	6	120	684
September 2016	32	9	219	471	23	20	1,833	0	0	3923	23	0	3923
October 2016	44	5	478	917	36	31	9,920	0	0	1173	14	403	1576
November 2016	35	11	123	703	33	20	1,175	0	8	447	7	312	767
Grand Totals	175	45	1,082	3,847	163	138	16,134	0	288	6220	61	2,623	9131

* Used to calculate Total Rehab Footage



PIPELINE MAINTENANCE TOTALS BY DATE COMPLETED - Monthly

July 01, 2016 to November 30, 2016

	Main Line Wash Footage	Service Line Wash Footage	Rod Line Footage	Cleaned Footage	CCTV Footage	Smoke Footage	SL-RAT Footage
2016							
July	45,193	2,360	6,542	51,735	20,983	32,171	20,618
August	75,579	1,531	12,085	87,664	26,074	42,442	17,103
September	105,454	1,456	11,406	116,860	12,671	26,129	16,406
October	66,420	2,175	10,127	76,547	17,277	46,276	21,969
November	35,682	3,046	12,831	48,513	21,342	13,076	9,061
Grand Total:	328,328	10,568	52,991	381,319	98,346	160,095	85,157
Avg Per Month:	65,666	2,114	10,598	76,264	19,669	32,019	17,031



CUSTOMER SERVICE REQUESTS

Monthly - All Crews

CREW	MONTH	JOBS	AVERAGE RESPONSE TIME	AVERAGE TIME SPENT
DAY 1ST RESPONDER				
	July, 2016	106	26	41
	August, 2016	127	27	37
	September, 2016	92	28	43
	October, 2016	111	34	39
	November, 2016	120	34	39
		556	30	40
NIGHT 1ST RESPONDER				
	July, 2016	14	21	49
	August, 2016	32	25	28
	September, 2016	10	25	16
	October, 2016	22	30	32
	November, 2016	12	29	28
		90	26	31
ON-CALL CREW *				
	July, 2016	35	48	37
	August, 2016	34	43	33
	September, 2016	22	48	54
	October, 2016	43	41	34
	November, 2016	49	51	40
		183	46	38
Grand Totals:		829	33	38

* On-Call Crew Hours: 8:00pm-7:30am Monday-Friday, Weekends, and Holidays

Planning & Development Project Status Report

Active Construction Projects Sorted by Work Location and Project Number

January 6, 2017

#	Project Name	Project Number	Work Location	Zip Code	Units	LF	Pre-Construction Conference Date	Comments
1	Isaac Dickson School Relocation	2013033	Asheville	28801	School	504	1/13/2014	Final Inspection complete, awaiting close-out docs
2	Robinhood Relocation	2013107	Asheville	28804	5	230	7/23/2015	Awaiting Conveyance of Sewer System
3	Hunt Hill Apartments	2013111	Asheville	28801	180	1,729	3/5/2014	Waiting on final inspection
4	Dillingham Woods	2014048	Asheville	28805	27	375	3/4/2015	Waiting on final inspection - Project delayed
5	A.B. Tech Fernhurst Relocation	2014061	Asheville	28801	Comm.	697	4/8/2014	Awaiting Conveyance of Sewer System
7	Franklin School of Innovation	2014096	Asheville	28806	School	359	11/4/2016	Final Inspection complete, awaiting close-out docs
8	Rivermill Lofts Relocation	2014125	Asheville	28803	254	314	8/21/2015	Waiting on final inspection
9	Shelburne Road	2014126	Asheville	28806	9	418	4/5/2016	Installing
10	Gibson Road (aka Four Seasons)	2014138	Asheville	28804	3	137	9/11/2015	Awaiting Conveyance of Sewer System
11	Conestee	2014149	Asheville	28801	7	113	8/7/2015	Waiting on final inspection
12	Craggy Park Ph. 1	2014164	Asheville	28806	45	1,935	10/23/2015	Final Inspection complete, awaiting close-out docs
13	Springside Road Townhomes	2015006	Asheville	28803	3	120	12/15/2015	Final Inspection complete, awaiting close-out docs
14	First Baptist Relocation	2015032	Asheville	28801	Comm.	333	7/21/2015	Final Inspection complete, awaiting close-out docs
15	Hall Avenue	2015035	Asheville	28806	8	329	3/4/2016	Waiting on final inspection
16	Cottages at Kenilworth	2015107	Asheville	28805	12	454	12/1/2015	Final Inspection complete, awaiting close-out docs
17	Ascot Point Apartments Phase 3	2015114	Asheville	28803	104	213	9/9/2016	Testing
18	8 Sulphur Springs Road	2015116	Asheville	28806	6	80	11/22/2016	Installing
19	The District	2015133	Asheville	28803	309	912	2/26/2016	Testing
20	Hampton Inn & Suites	2015144	Asheville	28806	Comm.	286	11/8/2016	Waiting on final inspection
21	Asheville Exchange	2015170	Asheville	28806	312	582	2/26/2016	Waiting on final inspection
22	Beale Road Subdivision (Habitat)	2015200	Asheville	28704	21	730	4/5/2016	Waiting on final inspection
23	Fairfield Inn & Suites - Tunnel Road	2015203	Asheville	28805	Comm.	350	4/29/2016	Waiting on final inspection
24	Upstream Way (aka Amboy) Ph. 2	2016254	Asheville	28806	11	402	10/20/2015	Pre-con held, construction not yet started
25	Rosebriar	2007005	Black Mountain	28711	12	309	8/28/2014	Waiting on final inspection
26	West Keesler Avenue	2007176	Black Mountain	28711	6	410	11/15/2016	Testing
27	Settings at Black Mountain	2008016	Black Mountain	28711	30	907	11/13/2015	Final Inspection complete, awaiting close-out docs
28	Cheshire Pocket Village	2015129	Black Mountain	28711	15	370	2/26/2016	Final Inspection complete, awaiting close-out docs
29	Tudor Croft (aka Roberts Farm) Ph.2	2016170	Black Mountain	28711	46	1,320	1/3/2017	Installing
30	Peregrine's Ridge	2006160	Buncombe Co.	28730	14	635	11/8/2016	Waiting on Deflection Test
31	Pinnacle at Arabella Heights	2006277	Buncombe Co.	28704	28	482	11/10/2015	Testing
32	Hyde Park Phase 2	2013058	Buncombe Co.	28704	14	500	12/3/2013	Waiting on final inspection
33	Givens Gerber Park	2014065	Buncombe Co.	28803	260	357	8/7/2015	Final Inspection complete, awaiting close-out docs
34	Creekside Cottages	2014095	Buncombe Co.	28704	7	504	3/12/2015	Final Inspection complete, awaiting close-out docs
35	Governor's Western Residence	2014100	Buncombe Co.	28804	Comm.	636	7/22/2015	Awaiting Easement Plat/Conveyance of Sewer System
36	Somerset at Walnut Cove	2015079	Buncombe Co.	28704	12	473	8/19/2016	Testing
37	Greymont Apartments	2015108	Buncombe Co.	28806	312	3,193	5/17/2016	Testing
38	Williams-Baldwin Teacher Campus	2015166	Buncombe Co.	28806	24	313	9/16/2016	Waiting on final inspection
39	Ball Gap Road	2015186	Buncombe Co.	28704	14	947	5/31/2016	Waiting on final inspection
40	The Haven at Enka Lake	2015191	Buncombe Co.	28715	259	1,595	9/27/2016	Waiting on testing
41	Greenwood Filelds Phase 1	2015204	Buncombe Co.	28804	158	2,830	6/16/2016	Installing
42	Newbridge Parkway Apartments	2016013	Buncombe Co.	28804	308	1,575	9/2/2016	Installing
43	Biltmore Lake Block I, Phase 2	2016042	Buncombe Co.	28803	26	1,297	8/5/2016	Final Inspection complete, awaiting close-out docs
44	Long Shoals Village Phase 2	2016109	Buncombe Co.	28704	Comm.	330	8/16/2016	Waiting on testing
45	Greenwood Park Phase 1	2014067	Weaverville	28787	7	283	9/1/2015	Final Inspection complete, awaiting close-out docs
46	Maple Trace Subdivision Phase 1	2014121	Weaverville	28787	31	2,420	1/29/2016	Final Inspection complete, awaiting close-out docs
47	Monticello Apartments	2015124	Weaverville	28787	168	1,484	6/14/2016	Installing
48	Crest Mountain Phase 3B	2013041	Woodfin	28806	69	1,329	10/15/2013	Waiting on final inspection
49	Serenity Falls Subdivision	2015055	Woodfin	28804	45	2,583	9/18/2015	Waiting on final inspection
50	Reese & Jan Lasher (High Hopes)	2015152	Woodfin	28806	14	320	4/26/2016	Punchlist pending, awaiting closeout documents
TOTAL					3,195	39,004		

CAPITAL IMPROVEMENT PROGRAM

STATUS REPORT SUMMARY

January 11, 2017

PROJECT	LOCATION OF PROJECT	CONTRACTOR	AWARD DATE	NOTICE TO PROCEED	ESTIMATED COMPLETION DATE	*CONTRACT AMOUNT	*COMPLETION STATUS (WORK)	COMMENTS
BYPASS PUMP STAGING AREAS	Woodfin 28804 and Asheville 28806	NHM Constructors, LLC	3/16/2016	4/11/2016	1/31/2017	\$307,455.72	98%	Project is nearing completion.
HENDERSONVILLE ROAD @ MILLS GAP ROAD	Asheville 28803	Terry Brothers Construction Company	3/16/2016	4/13/2016	12/31/2016	\$727,585.00	100%	Project is complete and in close out.
POINT REPAIR CONTRACT NO. 1	Various	Patton Construction Group	8/17/2016	9/12/2016	6/30/2017	\$166,820.00	40%	Project is progressing well.
SAND HILL ROAD @ RUSSELL / DAVENPORT	West Asheville 28806	Terry Brothers Construction Company	12/21/2016	12/29/2016	4/28/2017	\$425,089.00	0%	Contractor has mobilized and has begun clearing trees.
SOUTH FRENCH BROAD INTERCEPTOR - LINING	Biltmore Estate	SAK Construction, LLC	11/16/2016	1/3/2017	4/3/2017	\$457,710.00	0%	Contractor is scheduled to mobilize this week.
STRATFORD ROAD @ OXFORD COURT	Asheville 28804	Patton Construction Group	11/16/2016	1/3/2017	4/3/2017	\$216,700.00	0%	Contractor has mobilized.

***Updated to reflect approved Change Orders and Time Extensions**